

SERVICE MANUAL

3.5 INCH

MICRO FLOPPY DISK DRIVE

SF - 314

JULY, 1985

REVISION 1

CONTENTS

- Section 1 Major Components And Operating Principles**
 - 1-1 Major Components and General Specifications
 - 1-2 Read/Write Head Section
 - 1-3 Head Access Mechanism
 - 1-4 Cartridge Insert/Eject Mechanism
 - 1-5 Disk Chucking and Drive Mechanism
 - 1-6 Auto Shutter Open/Close Mechanism
 - 1-7 Index Sensor Section
 - 1-8 Write-Enable Sensor Section
 - 1-9 Disk Drive Motor Unit
 - 1-10 Track 00 Sensor Section
 - 1-11 Control Circuit Section
 - 1-12 Interface & Interface Board
 - 1-12-1 Interface Signals
 - 1-12-2 Power Supply and Interface
 - 1-12-3 Installation

- Section 2 Operation And Maintenance**
 - 2-1 Usage Notes
 - 2-2 Head Cleaning

- Section 3 Assembly, Disassembly And Parts Replacement**
 - 3-1 Required Tools
 - 3-2 Main Unit
 - 3-3 Front Bezel and Pushbutton
 - 3-4 Top Case Nameplate

- Section 4 Parts List And Assembly Diagram**

- Section 5 Circuit Diagrams**
 - 5-1 Main Board Circuit Diagrams
 - 5-2 Disc Drive Motor Circuit Diagrams
 - 5-3 T.F. Control Circuit Diagrams

Section 1 Major Components And Operating Principles**1-1 Major Components and General Specifications****1. Major components**

The SF-314 is a 3.5-inch floppy disk drive which combines high performance with small size, low weight, and low power consumption. The drive unit consists of the following ten major components, which are indicated in Fig. 1-1, Overall Block Diagram.

- 1) Read/write (R/W) head section
- 2) Head access mechanism
- 3) Cartridge insert/eject mechanism
- 4) Disk chucking/drive mechanism
- 5) Auto shutter open/close mechanism
- 6) Index sensor section
- 7) Write-enable sensor section
- 8) Disk drive motor unit sensor
- 9) Track 00 sensor section
- 10) Control circuit and interface (interface board)

The outline dimension of SMD-140A(FDD) and housing case are shown to Fig.1-2(SMD-130A) and Fig.1-3(housing case).

2. General specifications

Recording capacity:

Unformatted	500 Kbytes (FM), 1000 Kbytes (MFM)
Formatted (16sectors/track)	328 Kbytes (FM), 656 Kbytes (MFM)
Recording density	4360 BPI (FM), 8720 BPI (MFM)
Transfer rate	125 Kbits/sec (FM), 250 Kbits/sec (MFM)
Track density	135 TPI
Average latency	100 msec
Access time:	
Track-to-track	3 msec
Average	96 msec
Setting time	15 msec
Head load time	no head load mechanism
Number of tracks	160
Inside track radius (Side 0)	24.6875 mm
(Side 1)	23.1875 mm
Outside track radius (Side 0)	39.50 mm
(Side 1)	38.00 mm
Recording method	FM/MFM
Read/write (R/W) head	tunnel erase head
Number of heads	2
Head positioning method	stepping motor and ϕ -wound steel belt

Disk drive motor:

Type	radial-gap brush motor
Startup time	1 sec
Rotational speed	300 rpm

Detectors:

Index Sensor	Non-contact Detection method
Track 00 sensor	Non-contact Detection method
Write enable sensor	Contact Detection method

Environmental conditions (operating):

Temperature	5°C to 45°C
Humidity	20% to 80% RH(non-condensing)
Maximum wet-bulb temperature	29°C
Vibration	5 HZ to 60 HZ, 0.6 G max. (including Stand-by)

Environmental conditions (storage/transportation)

Temperature	-20°C to 65°C (storage) -40°C to 65°C (transportation)
Humidity	95% RH max. (non-condensing)
Vibration	5 Hz to 60 Hz, 3 G max.
Shock	50 G max.

Power supply:

+12V	stand-by	60 mA(typ.)
	read/write	300 mA(typ.)
	motor start-up	850 mA(max.)
+ 5V	stand-by	340 mA(typ.)
	read/write	380 mA(typ.)
	motor start-up	500 mA(max.)

Voltage tolerance

+12V	0 to 300mA	±5%
	300 to 850mA	±10%
+ 5%	0 to 400mA	±5%
	400 to 500mA	±10%

Power consumption:

Stand-by	2.4 W (typ.)
Read/write	5.5 W (typ.)

External dimensions:

Width	142 mm (5.6 inches)
Depth	239 mm (9.4 inches)
Height	62 mm (2.4 inches)
Weight	1,050 g (2.3 pounds)
Installation	refer to Fig.1-35

Reliability (read/write during standard office use)

MTBF	2,000 POH
MTR	0.5 hour
Design life	5 years
Software error rate	less than 10^9 bits
Hardware error rate	less than 10^{12} bits
Seek error rate	less than 10^6 seeks
Disk service life	3×10^6 passes/track min.

Recommended disk: 3.5-inch flexible disk

Sony	OM-D4440(double-sided)
Maxell	MF2-DD(double-sided)
Konishroku	TBD (double-sided)

1-2 Read/Write Head Section

The read/write (R/W) head is a high-reliability, tunnel-erase-type ferrite-ceramic head, which provides an erase gap on each side of the read/write gap. To control the erase crosstalk which occurs in tunnel-erase heads, the azimuth of the erase gap has been optimized.

See Fig.1-4

1-3 Head Access Mechanism

A low-power, high-precision stepping motor and an α -wound belt have been adopted to position the read/write head.

See Fig.1-5,6

The step response time of the SF-314 is set up as follows. Since one step is required per track, the levels for the phase 0 to 3 signals are shown in the following diagram.

See Fig.1-7

1-4 Cartridge Insert/Eject Mechanism

The following sequence of operations is commenced when the cartridge is lightly inserted into the insertion slot on the front bezel.

- 1) The auto shutter is opened.
- 2) The cartridge is lowered and the hub in the center of the disk is pushed against the chucking hub.
- 3) The pad is lowered against the disk surface, and the head is loaded.
- 4) The write-enable sensor operates.
- 5) The disk drive motor starts.
- 6) Chucking and centering of the disk are performed.

At this point, the drive unit waits for a signal from the host system.

The read/write head remains loaded until ejection is commenced.

To remove the cartridge from the drive, the eject button on the lower right of the front bezel is pushed. At this time, the force required to push the button may be higher than when the cartridge is inserted. This results from slight mechanical differences and is not an abnormality.

See Fig.1-8

1-5 Disk Chucking and Drive Mechanism

Disk chucking begins after cartridge insertion has been completed and simultaneously with motor activation.

In the chucking operation, (1) the spindle enters the center of the disk, (2) the hub is held down by magnets, and (3) the drive roller enters the drive hole. When the drive roller enters the hole, it pushes the hub to the outside. The combination of this force with the frictional resistance received from the head pushes the specific square hole in the center of the hub against the spindle, thus centering the disk with high precision.

Accordingly, any deformation or foreign materials on the square hole or spindle will result in the loss of compatibility between disk drives.

The disk is driven by the drive roller, while the chucking magnets stabilize disk rotation by holding the hub firmly against the spindle.

1-6 Auto Shutter Open/Close Mechanism

When the cartridge is inserted in the drive, the shutter pin strikes the cartridge immediately to the side of the shutter. As the cartridge is further inserted, the shutter lever pivots and the shutter pin pushes the shutter to the side, opening it. Just before the cartridge strikes the rear of the holder, the head window is fully open. Immediately after that, the shutter pin enters the deep groove in the cartridge and locks. (See sec.1-4, Cartridge Insert/Eject Mechanism.)

See Fig.1-10

When the cartridge is ejected, this operation is reversed. As the holder rises, it moves toward the front bezel. At this time, inertia causes the cartridge to fly in the same direction. When the cartridge has gone a certain distance, the shutter pin is released from the groove. The combined force of the shutter lever spring and cartridge shutter spring pushes the shutter pin back, thus closing the shutter over the head window.

As shown in Fig.1-11 when the cartridge is inserted backwards or upside-down, the shutter pin is pushed forward more than normally, causing the shutter lever on the opposite side to catch on the left holder guide (L) and thus preventing insertion of the cartridge.

See Fig.1-11

If the cartridge is inserted at an angle instead of flat, it will catch partway on the holder, the shutter lever pin will catch on the main frame, and the cartridge cannot be inserted further.

See Fig.1-12

1-7 Index Sensor Section

The start of data on a read/write track (the start position) is determined by the index sensor section. This section consists of a permanent magnet mounted on the outside of the disk drive motor roter and a Hall element mounted on the motor control circuit board. One-pulse signal is generated on each revolution.

The index sensor is positioned by adjusting the timing between the index signal pattern written on the standard disk and the index signal.

See Fig.1-13

1-8 Write-Enable Sensor Section

The write-enable sensor section determines the write-enable notch on the cartridge is closed or open. It consists of a permanent magnet and a reed switch.

When the write-enable notch is closed, the permanent magnet at the end of the magnet arm is separated from the reed switch, turning the reed switch off. In this condition, the disk is write-enabled.

When the write-enable notch is open, the magnet rests against the reed switch, turning the reed switch on.

In this condition, the disk cannot be written to.

See Figs.1-14,15

1-9 Disk Drive Motor Unit

The SF-314 uses a flat, brush direct-drive motor for the disk drive motor. (See Fig.1-16)

The motor consists of a mechanical section, which uses a frequency-generator (FG) magnet as the rotor, and a control circuit section, which includes a frequency generator circuit. In addition the control circuit section includes (1) a motor speed control circuit, (2) a start-stop control circuit, and (3) a motor driver circuit.

When "low" signal is input, to the start/stop circuit, the driver chip in the motor driver circuit goes on and the disk drive motor starts.

When the disk drive motor starts, the speed sensing signals generated in the FG circuit by the FG magnet are input to the motor speed control circuit, where they maintain the disk drive motor at a fixed speed by controlling the driver chip in the motor driver circuit.

Finally, when "high" signal is input to the start/stop control circuit, the driver chip in the motor driver circuit goes off and the disk drive motor stops.

1-10 Track 00 Sensor Section

The track 00 sensor section generates a low signal when the read/write head is over the outermost track on the disk (the track 00 position). This provides a standard for positioning the head over other tracks.

See Fig.17

1-11 Control Circuits

The circuits which electrically control the operation of the various sections are separated into the main printed circuit board and the drive motor printed circuit board.

The control circuits can be broadly classified as follows:

- 1) Read/write logic and amplifier circuit
- 2) Stepping motor control circuit
- 3) Track 00 sensor circuit
- 4) Power-saving circuit
- 5) Index sensor circuit
- 6) Write-enable sensor circuit
- 7) Drive select circuit
- 8) Side select circuit

Most of these circuits have been integrated into a custom chip, as shown in Figs. 1-18, 1-19

1-12 Interface and Interface Board

1-12-1 Interface Signals

The SF-314 allows up to two drive units to be connected in daisy-chain configuration. All input signal levels are TTL compatible.

The drive requires +12V and +5V supplies for driving the unit and inputting and outputting signals.

(1) Electrical specifications for input signals

Signal identification conforms to the following levels.

"Low" =	true	Vin: 0V to +0.4V
		Iin: differs for the five types below
"High" =	false	Vin: +2.5V to +5.25V
		Iin: 0mA (typ.)

See Fig.1-20

(2) Input signals and their functions

1) Drive Select 0-1 (DS0, DS1)

Up to two SF-314s can be connected in a daisy chain using the IN/OUT terminals on the rear panel of the drives. The individual device numbers are set using connector SS1 on the main board. In this case, signal exchange is conducted only with the selected drive.

DS0 and DS1 are the drive select signals.

2) Direction (DRTN)

The Direction signal control the direction of read/write head movement by controlling the direction in which the stepping motor rotates. When the signal is "low", the read/write head moves toward the center of the disk; when "high", the head moves toward the outside.

3) Step (STP)

When the Step signal goes low, the stepping motor steps the read/write head in the direction specified by the Direction signal. The response time (T_s) must be at least 3 ms per track. However, this operation is inhibited when the Write Gate signal is low.

When reversing the stepping direction, the step pulse for the new direction must be sent at least " T_s + the settling time" after the preceding step pulse.

See Fig.1-21

4) Write Gate (WTG)

The Write Gate signal selects the Read Data or Write Data signal. When high, the Read Data signal is valid; when "low", the Write Data signal is valid.

When the slide-type write-enable notch on the cartridge is open, writing to the disk is inhibited by the circuitry. In order to provide time to obtain erase timing, seek and read operations must be started 1.3ms after the Write Gate signal has risen from "low" to "high".

5) Write Date (WTD)

The Write Data signal carries the write signals to the disk. when the input pulse falls from "high" to "low", the polarity of the write current flowing in the read/write head is reversed.

This signal is valid only when the Write Gate signal is "low".

See Fig.1-22

6) Side Select(SSL)

This signal selects whether the upper or lower Read/Write head will be used

"Low" = Side 1 (upper head)
 "High" = Side 0 (lower head)

(3) Electrical specifications for output signals

The SF-314 uses the SN7438 (Texas Instruments) or equivalent as the output driver.

"Low" = true Vin: 0 to +0.4V
 Iin: 40mA (max)

"High" = false Vin: +2.5V to +5.25V
 Iin: 0mA (open)

See Fig.1-23

(4) Output signals and their functions

1) Track 00 (TK00)

The Track 00 signal goes "low" when the read/write head is positioned over the outermost track on the disk (track 00).

2) Index (IDX)

The Index signal is output once at each revolution of the disk and is the standard signal used for the timing of various operations. The start of the track is indicated by the rising edge of this signal.

See Fig.1-24

3) Read Data (RDD)

The Read Data signal consists of the raw data pulse train read out by the read circuit. the signal goes "low" when the magnetic polarity on the disk surface reverses.

See Fig. 1-25

4) Write Enable (WE)

The Write Enable signal is low when the write/enable notch on the cartridge is open or knocked out. In this condition, writing to the disk is inhibited.

(5) Operation Timing

- | | |
|-----------------------|--------------|
| 1) Seek Timing | See Fig.1-26 |
| 2) Read Start Timing | See Fig.1-27 |
| 3) Read Data Timing | See Fig.1-28 |
| 4) Write Start Timing | See Fig.1-29 |
| 5) Write Data Timing | See Fig.1-30 |

(6) Control Signal Timing

In the timing chart below, the cartridge is set and the read/write head is positioned over track 00.

See Fig.1-31

1-12-2 Power supply and Interface

1. Connections

The SF-314 is connected to the host through two connectors: a power cable connector and a signal cable connector.

1) Power cable connector

See Figs.1-32,33

2) signal cable connector

See Fig.1-34

1-12-3 Installation

See Fig.1-35

Section 2 Operation Maintenance**2-1 Usage Notes**

No particular maintenance is required in normal daily use. For safety reasons, the following items should be checked when the unit is used for long periods of time.

1. Liquids and Metal Objects

Do not allow liquids or metal objects such as paper clips to get inside the unit. they may cause damage.

2. Connector Connections

Make certain that all power and signal cable connectors are correctly connected.

3. Shock and Vibration

The SF-314 is a precision instrument. therefore, do not place it in locations where it would be subject to strong shocks or vibrations.

4. Extreme Heat and Cold

Do not place the unit in direct sunlight or near heating equipment.

Do not place the unit where it is subject to extreme heat or cold or to rapid changes in temperatures in the drive housing or abnormal interior temperatures may result. Place the unit in a well-ventilated place.

Avoid extreme humidity and dust.

5. Electromagnetic Noise

A floppy disk drive may function improperly under the effect of electromagnetic noise. Do not place the unit near television sets, speakers, or other sources of electromagnetic energy.

6. Dirt on Housing

wipe accumulated dirt off the housing using a soft cloth. Wet the cloth with water and mild detergent and wring thoroughly before using. Do not use chemical agents such as paint thinner or benzene to clean the housing. they may cause discoloration or deformation.

2-2 Head Cleaning

From a functional viewpoint, head cleaning should be kept to a minimum. However, the occurrence of read errors or scratches on the disk surface indicate that there may be dirt on the head. In this case, use a cleaning disk to clean the head as follows.

1. Recommended cleaning disk

MIPOX 3.5-inch Head Cleaning Diskette (Nihon Microcoating)

2. Cleaning procedure

- 1) Turn the power to the drive on and insert the cleaning disk.
- 2) Cause the head to seek to improve the cleaning effect.
- 3) Clean for 30 seconds to one minute and remove the cleaning disk.
- 4) Insert a normal disk and confirm that read errors do not occur. If cleaning is still insufficient, repeat steps (1)-(3) above up to three times.

Section 3 Assembly, Disassembly And Parts replacement

Mistakes in following the assembly and disassembly procedures for the SF-314 may result in damage to parts. Please read the procedures carefully before proceeding.

3-1 Required Tools

The following tools are required for disassembling and assembling the SF-314.

NAME	STANDARD
Pin set remove for pushbutton (+) Screw driver Torque driver	#1

3-2 Main Unit Disassembly and Assembly

1. Disassembly

- 1) Turn the drive unit over and remove the top case holding screws (a) and the floppy disk drive holding screws (b).

See Fig.3-2

- 2) Hold the bottom case by the front and rear and pull up carefully. (Check that all seven holding screws are fully removed; failure to do so may damage the case.)

See Fig.3-3

- 3) Remove the floppy disk drive and cable assembly from the main unit by pulling it slightly to the rear, then up. (Make certain that the front bezel and pushbutton do not catch on the housing case.)

See Fig.3-4

- 4) Remove the cable connectors (J1-P1 and J2-P2) from the floppy disk drive. since the connector on the cable is soldered, do not attempt to remove it. When removing the cables, hold them by the connector part, not the cable itself.

See Fig.3-5

- 5) Remove the shield cover holding screws (2) and remove the shield cover from the floppy disk drive. When removing, hold the front bezel and check that the shield cover does not catch on cables or other parts.

See Fig.3-6

2. Assembly

- 1) Set the shield cover on the floppy disk drive and tighten the shield cover holding screws (2). do not set the shield cover upside down; the side with the three screw holes is the bottom.

See Fig. 3-7

- 2) Connect the cable connectors (J1-P1) and (J2-P2).

Be careful of the connector orientation when connecting.

See Fig.3-8

- 3) Insert the floppy disk drive carefully in the top case.

(Note: Check that the front bezel is set properly in the front of the top case. check that the holes in the connector board are set over the screw holes in the topcase.)

See Fig.3-9

- 4) Set the bottom case on the top case and tighten the top case holding screws (a) and bottom case holding screws (b).

Holding screw torque:

a: approx. 4 kgcm

b: approx. 4 kgcm

check that the bottom case is oriented properly before inserting the holding screws and check that the proper holding screw are used.

See Fig.3-10

3-3 Front Bezel and Push button

1. Disassembly

- 1) Remove floppy disk drive from housing case (see procedure 3-2, Disassembly).
- 2) remove front bezel holding screws (a) and remove the front bezel.

See Fig. 3-11

- 3) Pinch together the pushbutton holding prongs with tweezers from the rear of the floppy disk drive and remove the pushbutton.

See Fig.3-12

2. Assembly

- 1) Set the front bezel on the front of the floppy disk drive and tighten the front bezel holding screws (a) (torque = approx. 4 kgcm). When setting the front bezel, check that the front edge of the main board fits into the slot in the front bezel. While tightening the front bezel holding screws, push the front bezel tightly to avoid space between the holder guides and the front bezel.
- 2) Insert the pushbutton until the holding prongs catch firmly.

See Fig.3-13

3-4 Top case Nameplate

1. Disassembly

- 1) Remove the top case (see procedure 3-2, Disassembly).
- 2) Use a screwdriver to push out the nameplate from the rear of the top case.

Note: The nameplate on the bottom case contains the unit serial number. Do not remove this nameplate.

2. Assembly

- 1) Use double-sided tape to stick the nameplate to the top case. Check that the nameplate is properly positioned.
- 2) Set the pushbutton on the floppy disk

Note: Check that the pushbutton holding prongs is connected with the push button holding hole on the slider.

See Fig.3-14

Section 4 Parts List and Assembly Diagram

Table 4-1 SF-314 Parts List

Parts Code No. No.	Parts Name	Specifications	Number	Rate of Service parts
130A50100	Top case (w/nameplate)		1	0.01%
130A50200	Top case nameplate		(1)	0.01%
130A50300	Bottom case (w/nameplate, rubber leg)		1	0.01%
130A50400	Bottom case rubber leg		(4)	0.01%
130AQ1000	Cable connector		1	0.5 %
130A50700	Shield cover		1	0.01%
130AA6000	Front bezel		1	0.01%
130A00320	Pushbutton		1	0.01%
OCS20500	Holding screw (front bezel)	CSM2x5	2	0.1 %
OCB30300	Holding screw (case)	Set screw CB3x30 S20 (guide support)	4	0.1 %
OCB30160	Holding screw (FDD)	cross-recessed machine screw CBM3x16	3	0.1 %
OCB30060	Holding screw (shield cover)	cross-recessed machine screw CBM3x6	2	0.1 %
SF-31400	Floppy disk drive (SMD-140A)		1	0.3 %

Note: Number of Service parts is Rate by the number of Shipped SF314.

Section 5 Troubleshooting Program**5-1 Objective**

The troubleshooting program is designed to be used in the maintenance of the floppy disk drive unit for the Atari terminal. It can analyze failed configuration components (floppy disk drive, interface board).

5-2 Configuration**1. Voltage Check**

Operation: Causes the M-ON signal to go active (low) and the drive to seek from track 00 to track 79.

Check operation:

Checks the voltages at the interface board and floppy disk drive power supply terminals with a synchroscope and determines whether the voltage and ripple are within specifications.

2. IPD, DS, M-ON, DIR, STEP Signal Check

Operation: Same as 1 above.

Check operation:

- 1) IPD: frequency measurement (approx. 200 msec)
- 2) DS: DS signal is "low".
- 3) M-ON: M-ON signal is "low".
- 4) DIR

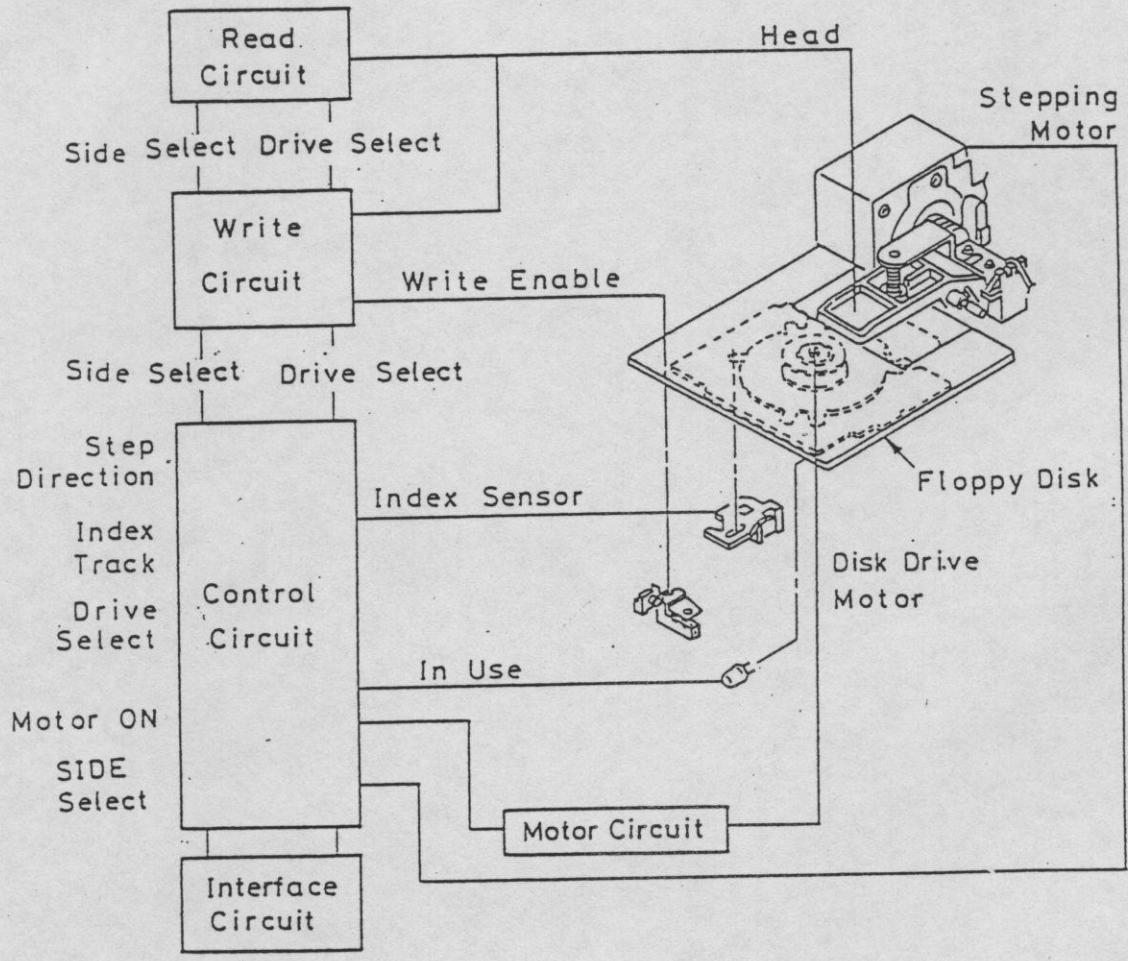

Fig. 1-1 : General Block Diagram

Outline Dimension Drawing

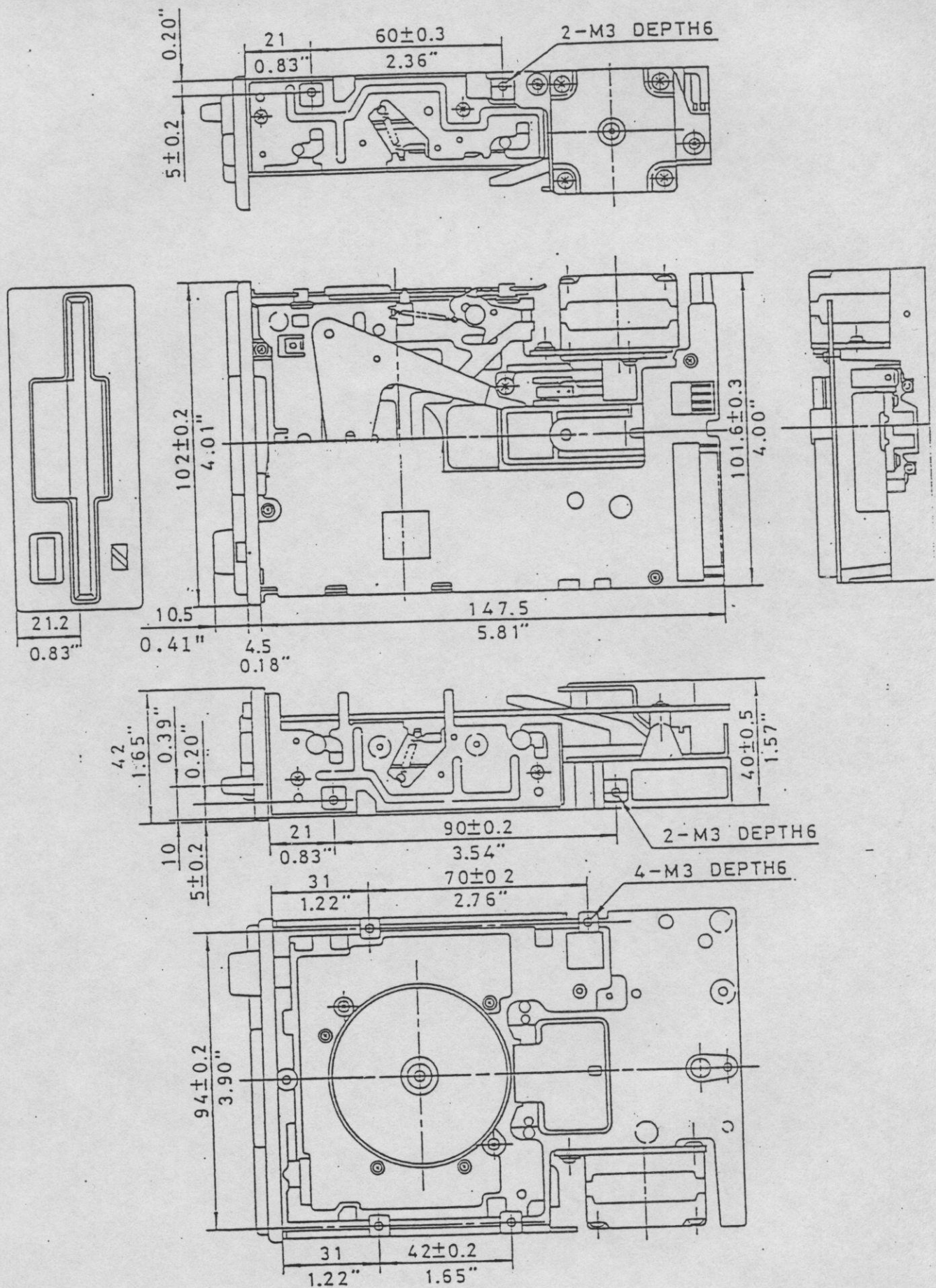

Fig. 1-2 : Outline Dimension

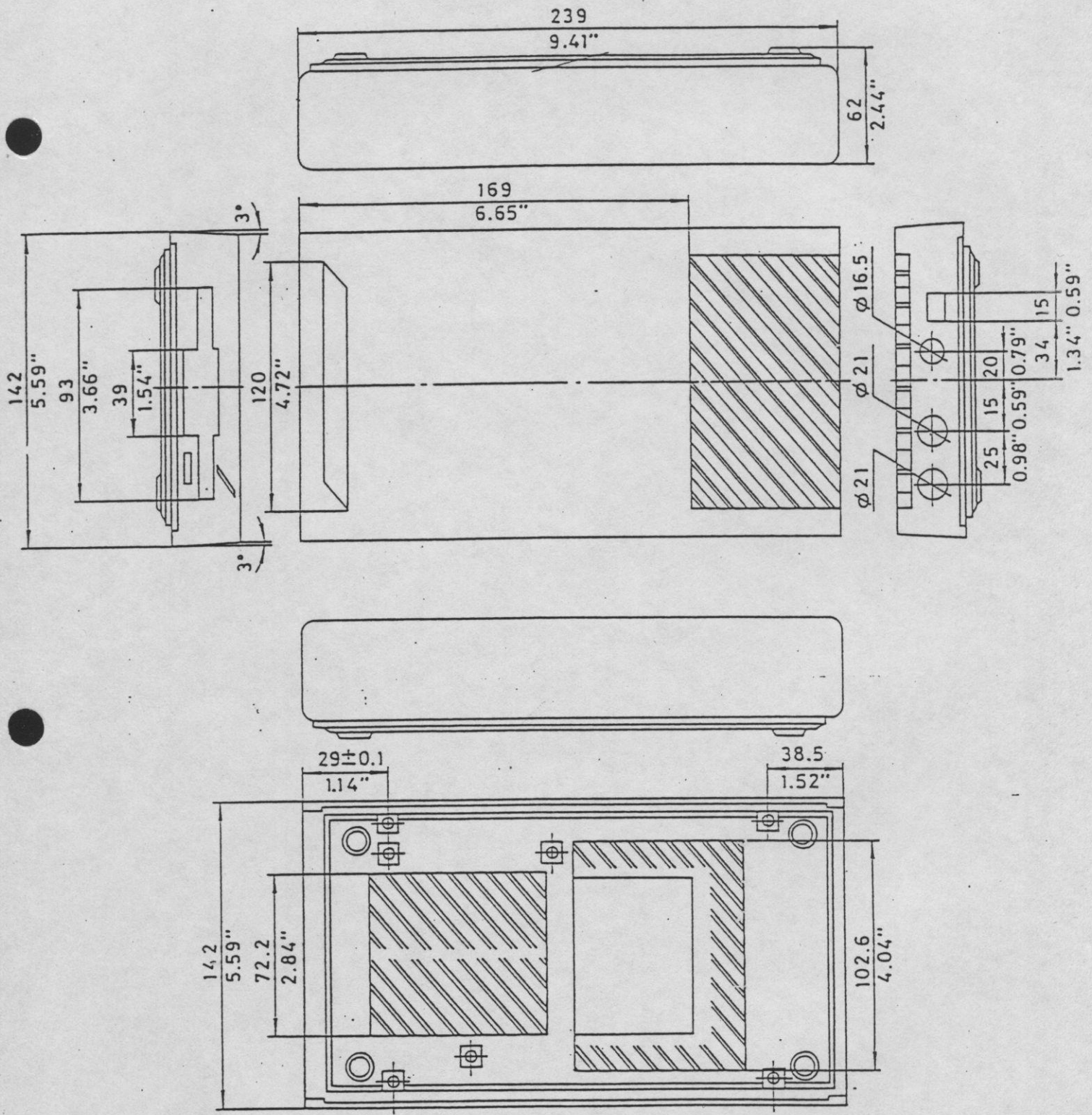

Fig. 1-3 : Outline Dimension (Housing)

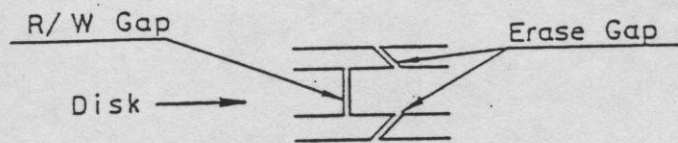
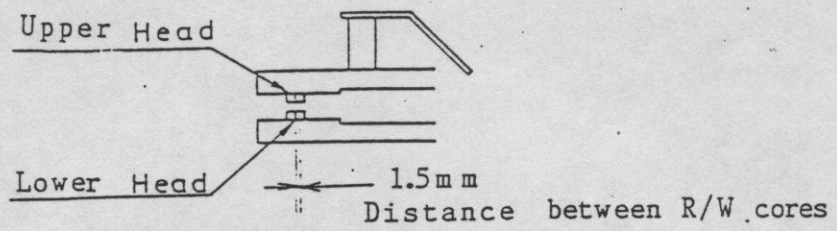

Fig. 1-4 : Read/Write Head & Pad

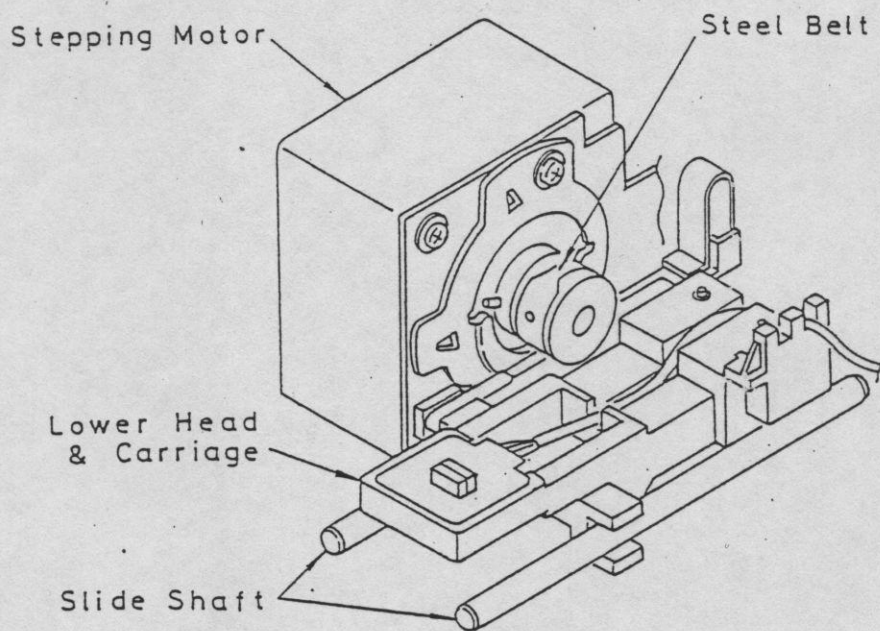

Fig. 1-5 : Head Access Mechanism

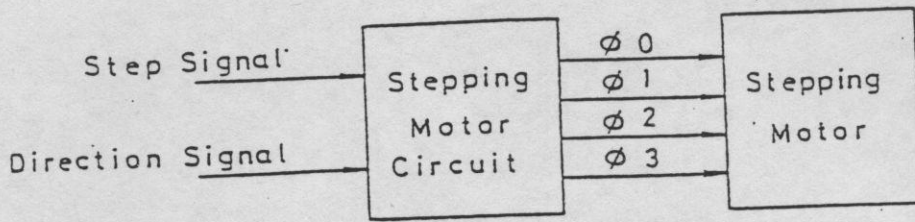

Fig. 1-6 : Head Access Diagram

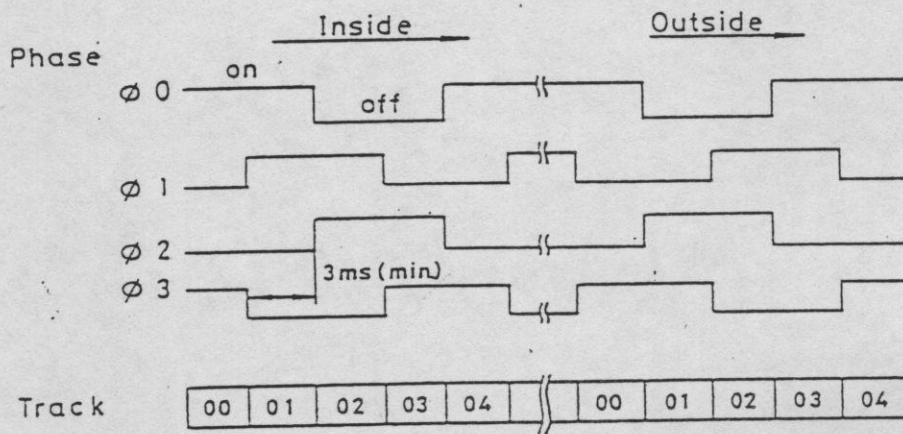

Fig. 1-7 : Stepping Action Diagram

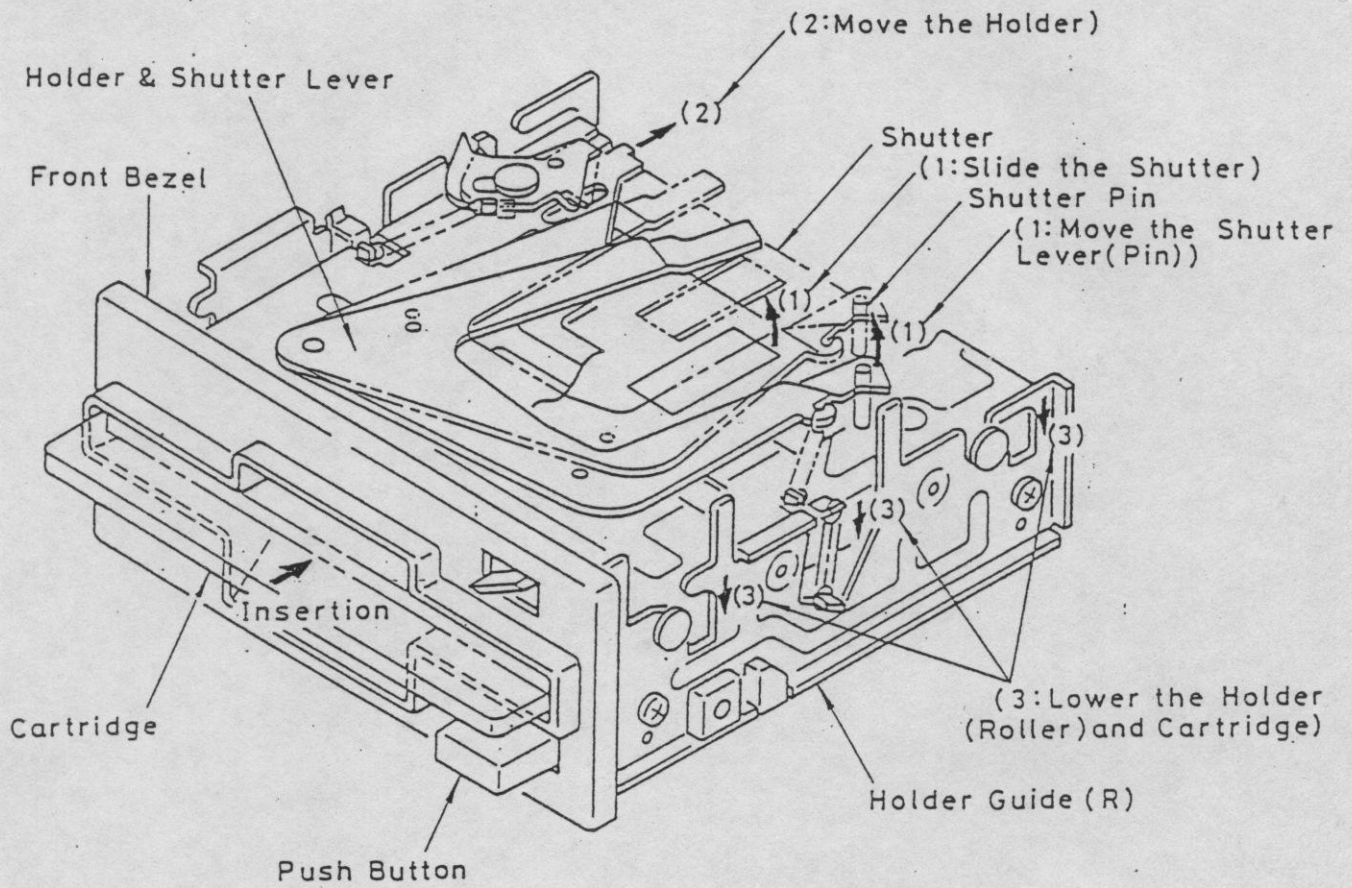

Fig. 1-8 : Cartridge In/Eject Mechanism.

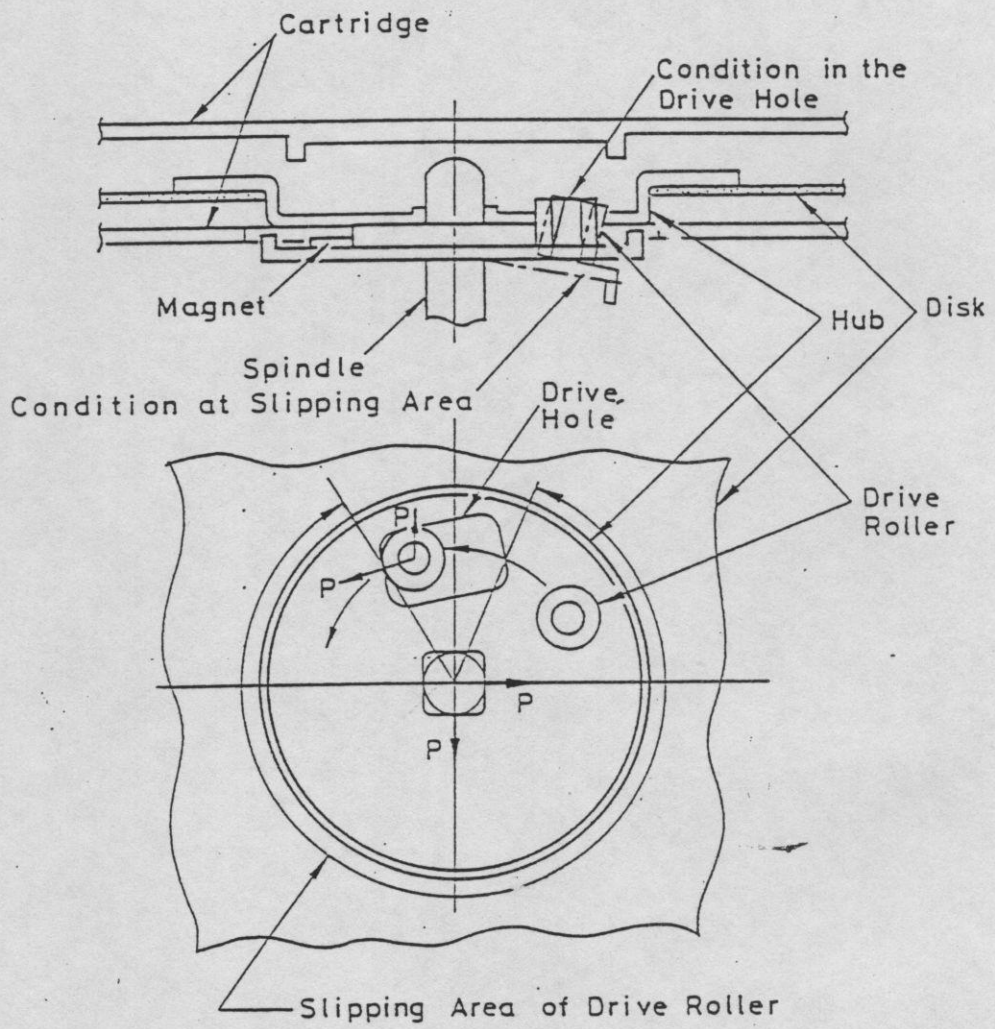

Fig. 1-9 : Disk Chucking & Drive Mechanism

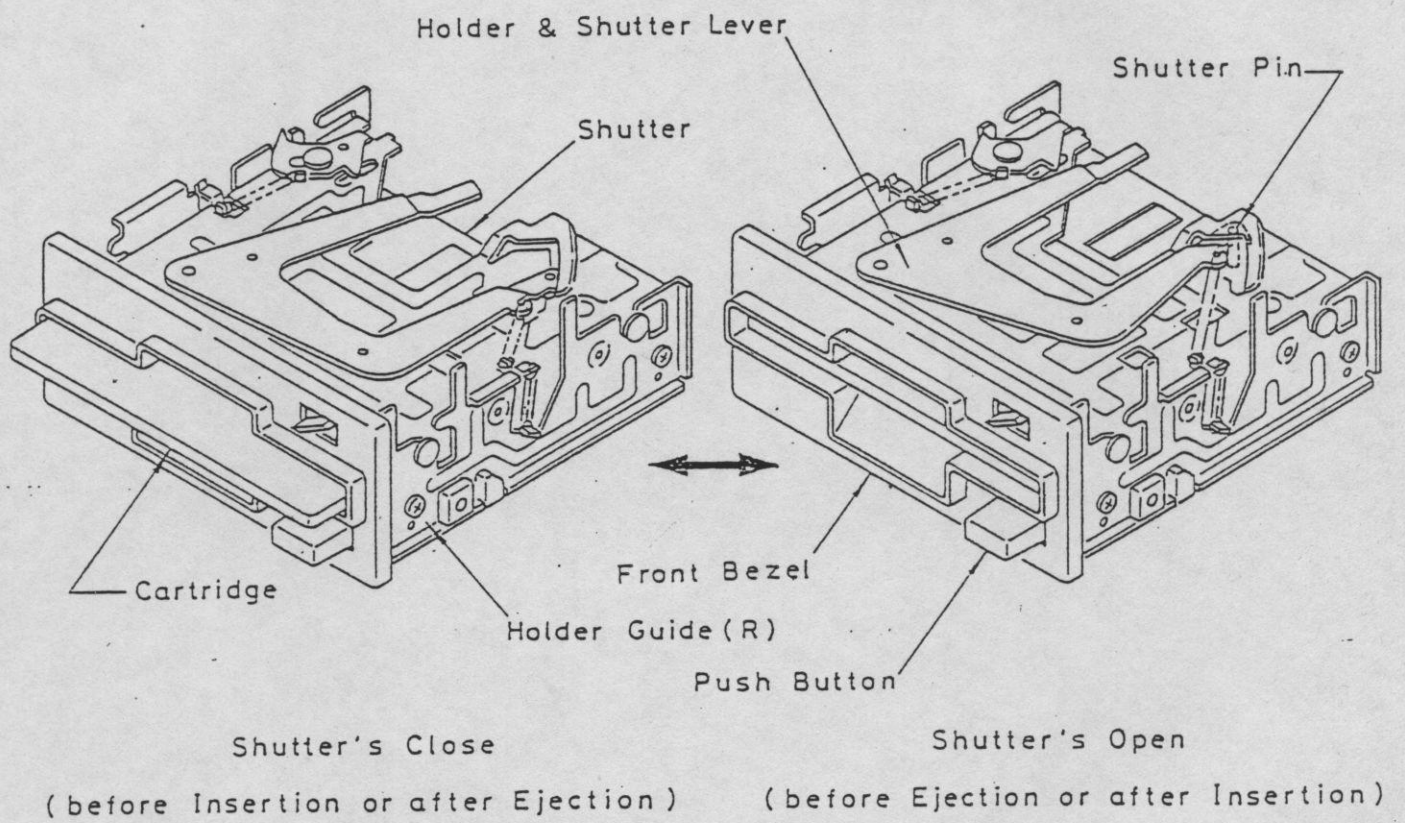

Fig. 1-10 : Shutter Operation

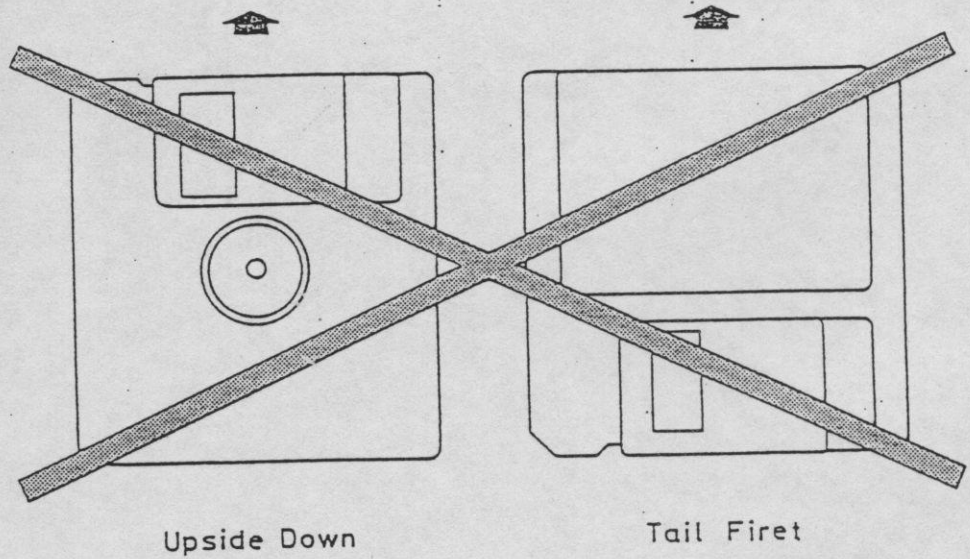
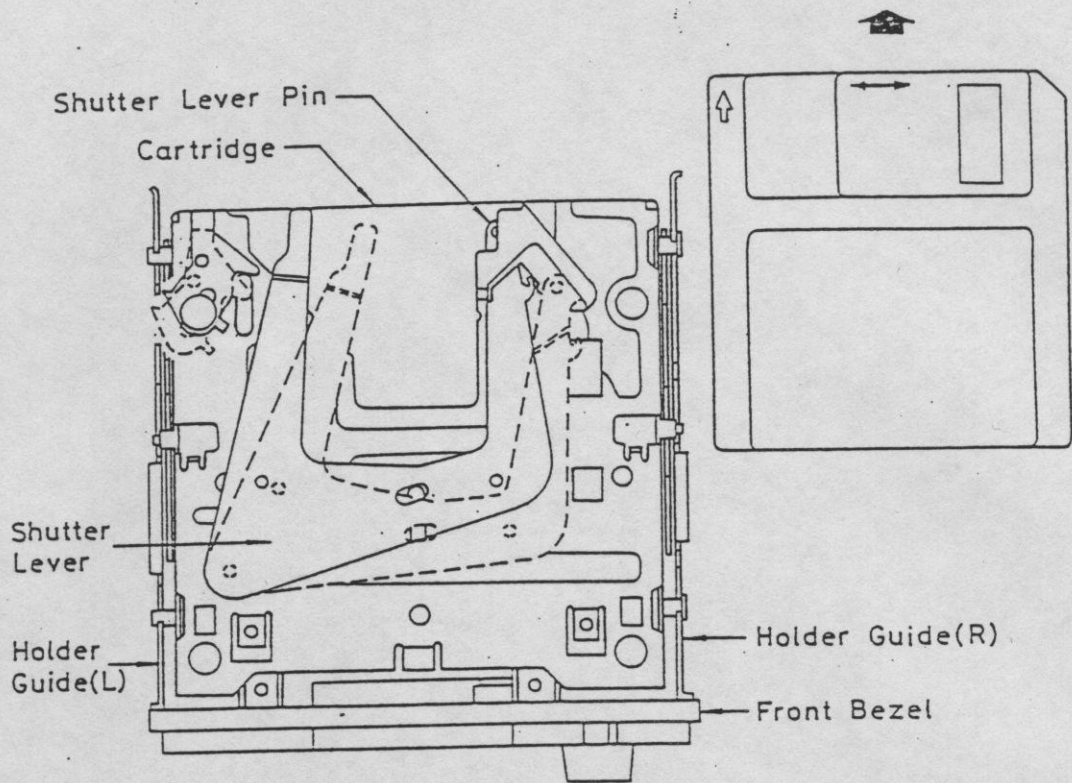

Fig. 1-11 : Cartridge Insertion

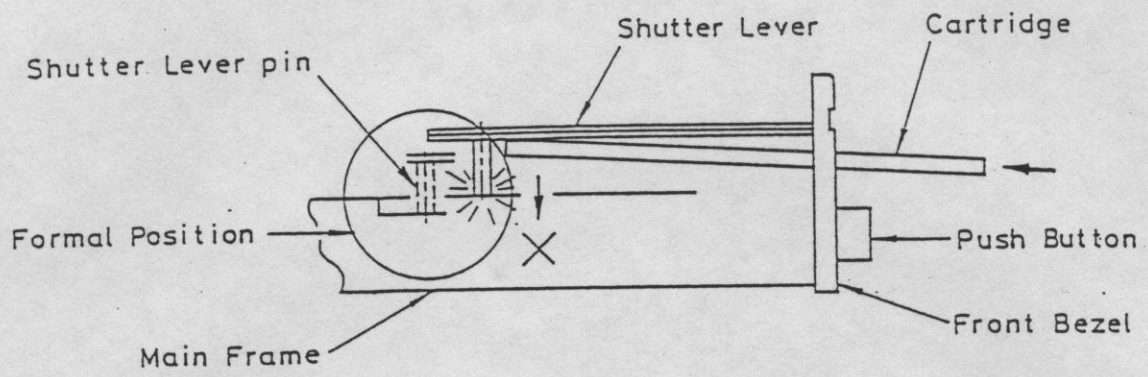

Fig. 1-12 : Oblique Insertion

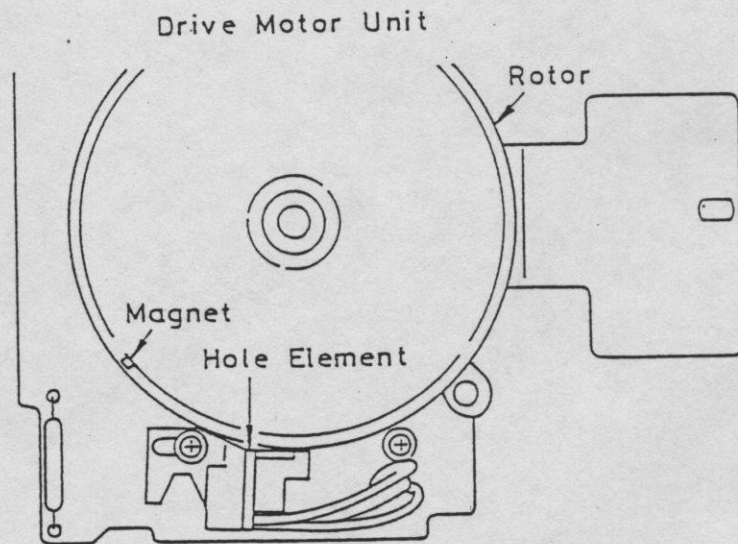

Fig. 1-13 : Index Sensor

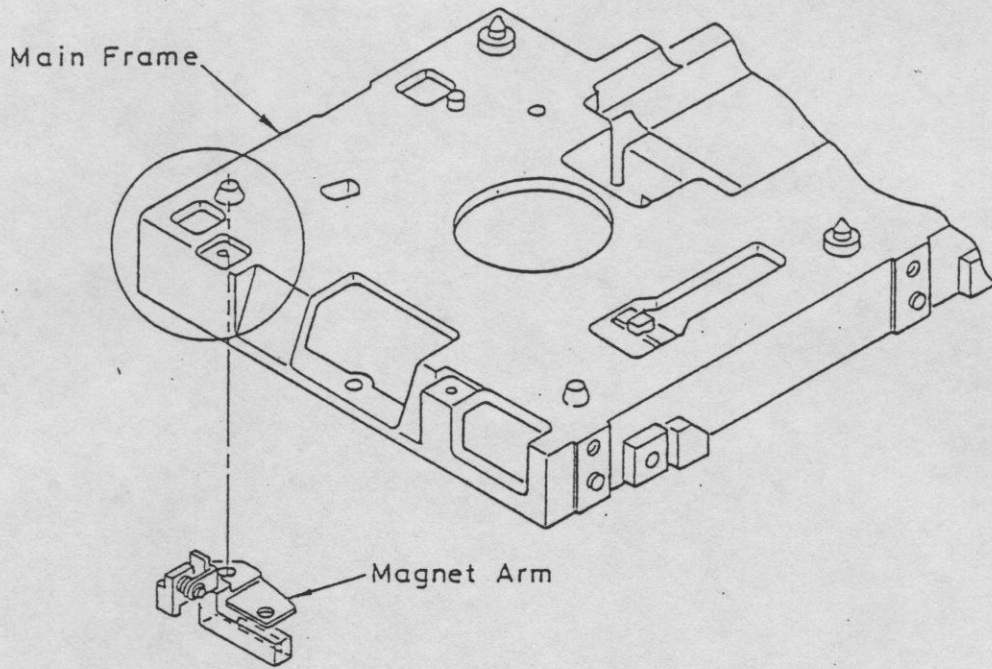

Fig. 1-14 : Write Enable Sensor

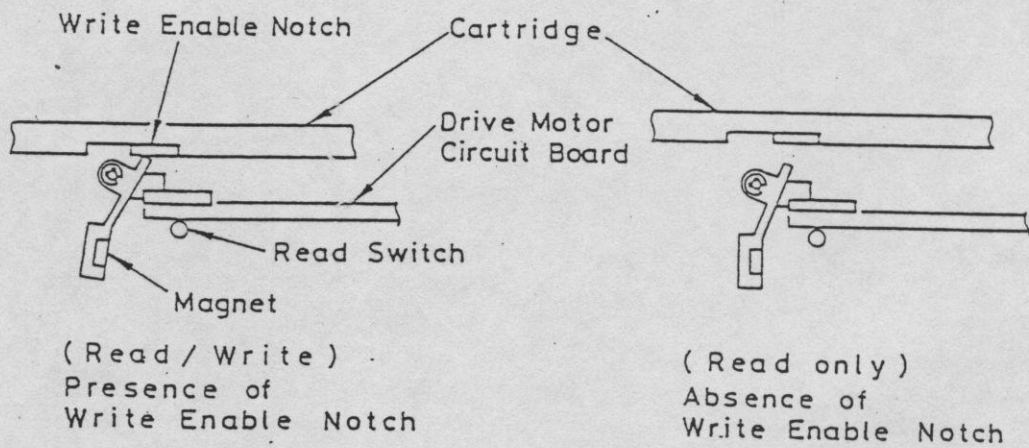

Fig. 1-15 : Magnet Arm Operation

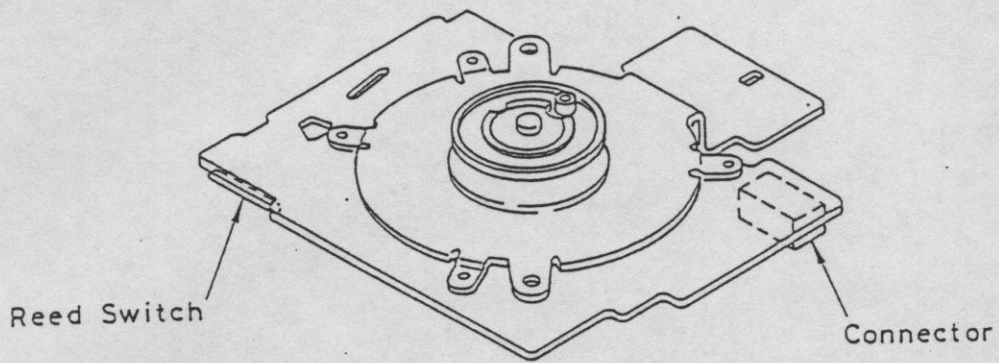

Fig. 1-16 : Disk Drive Motor Unit

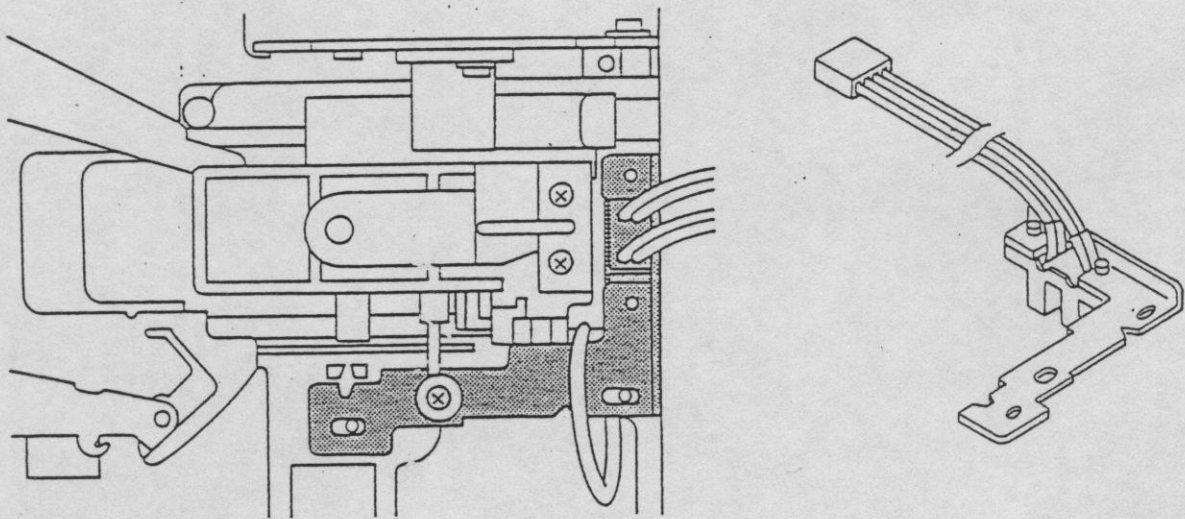

Fig. 1-17 : Track00 Sensor

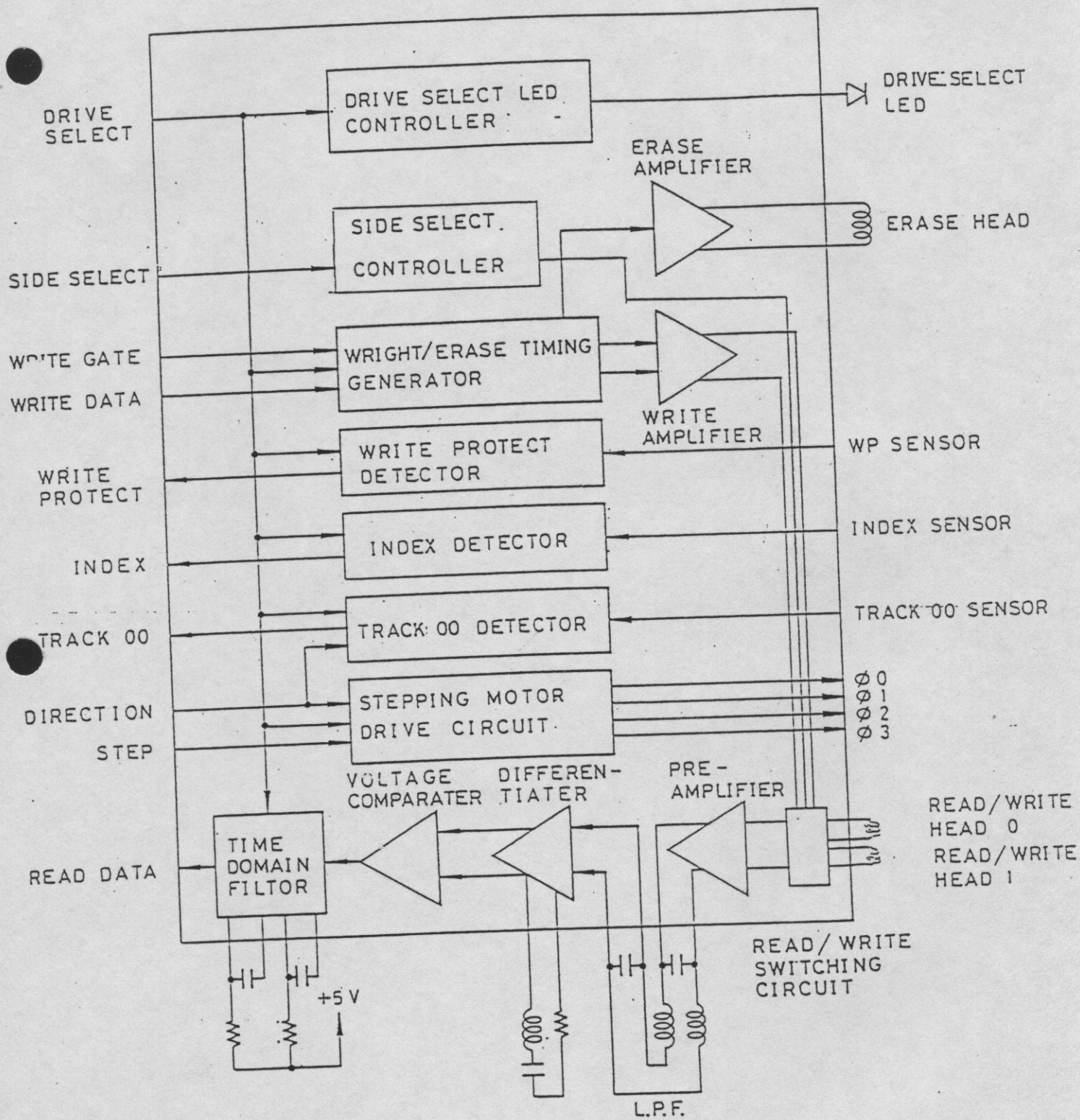

Fig. 1-18 : Control Circuit

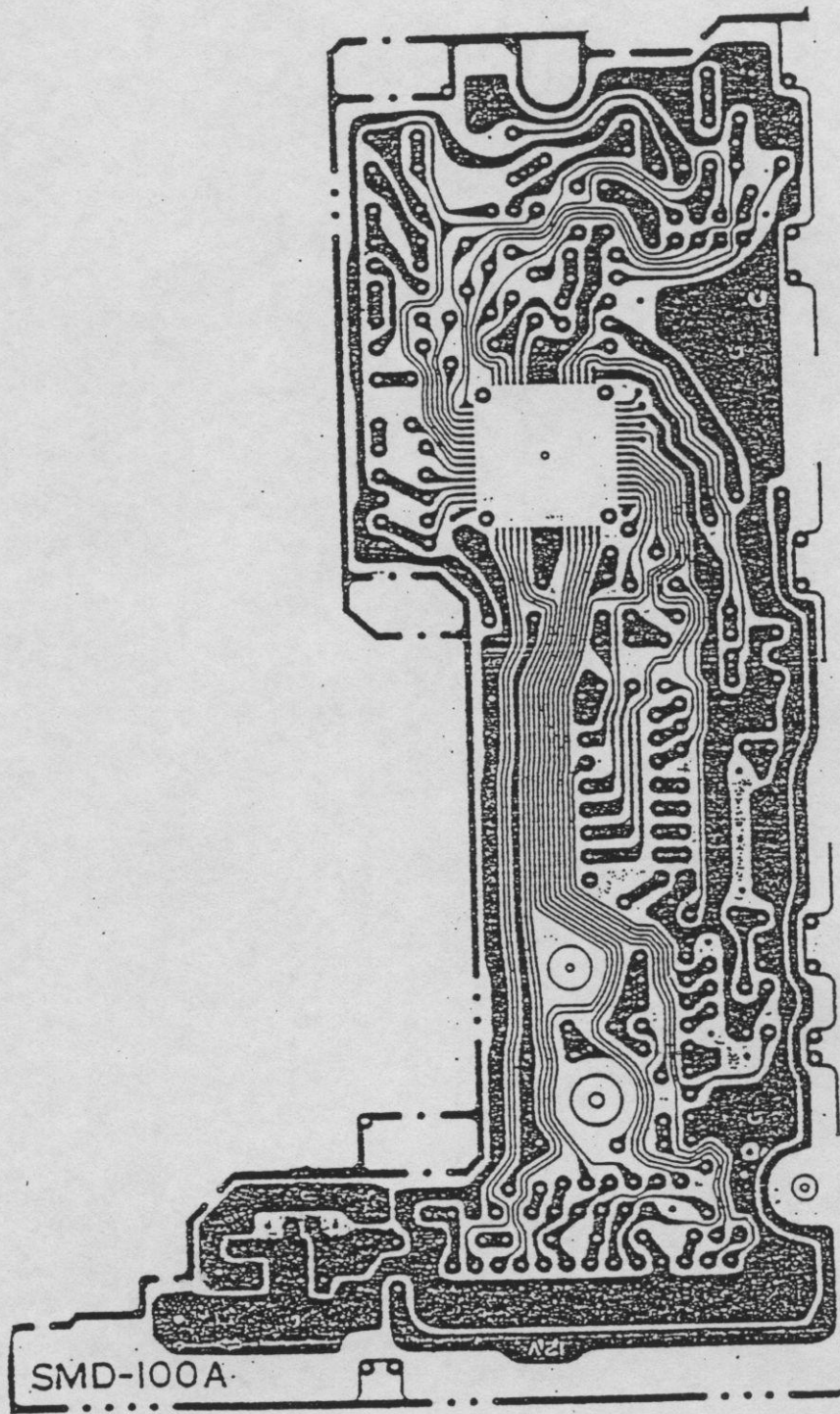

Fig. 1-19 : Main Circuit Unit Pattern

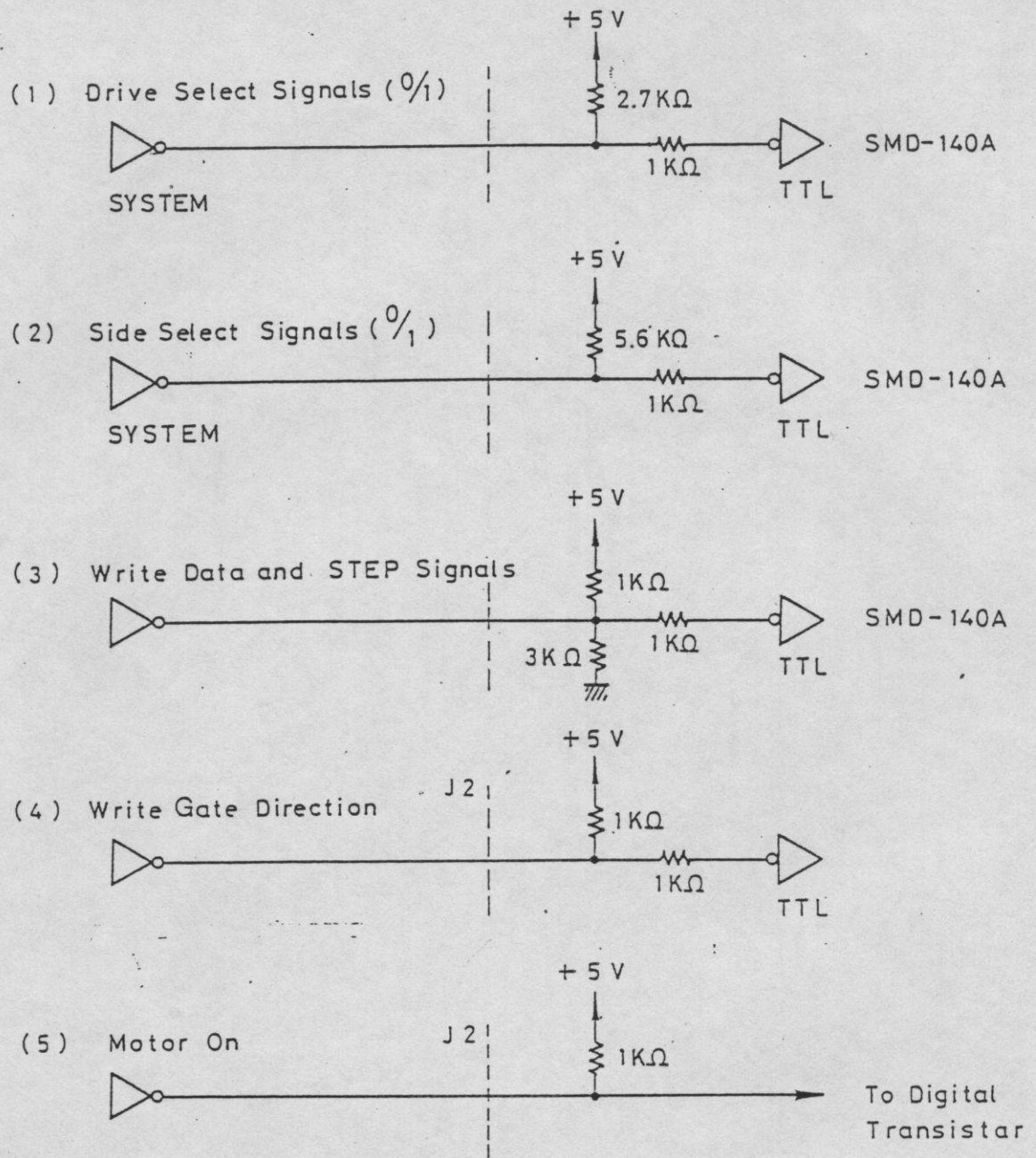

Fig. 1-20 : Interface Line (Input)

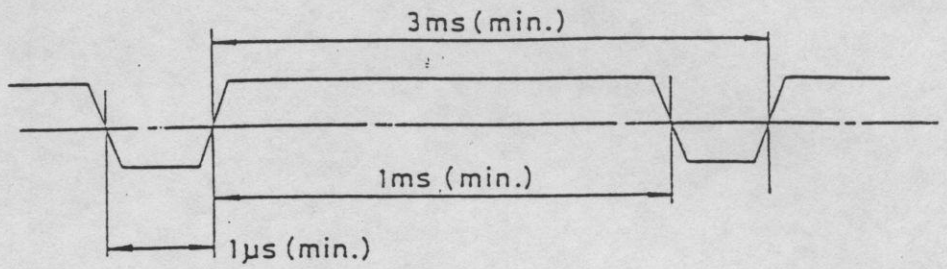

Fig. 1-21 : Step Pulse

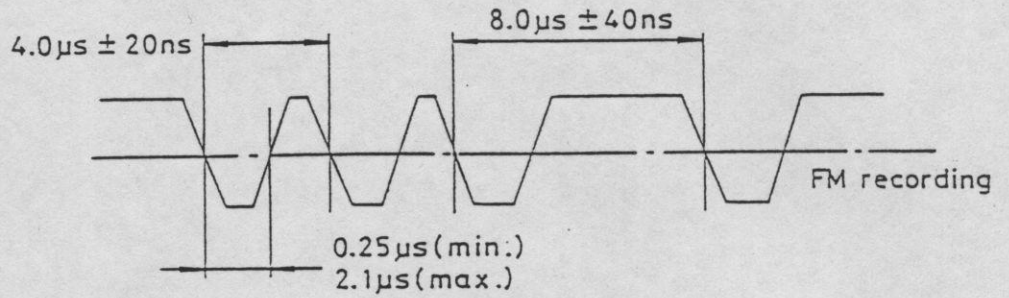

Fig. 1-22 : Write Data

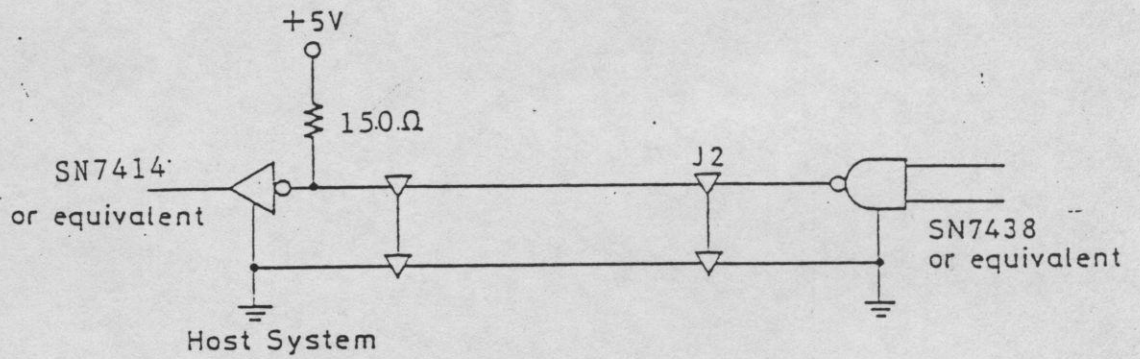

Fig. 1-23 : Interface Line (Output)

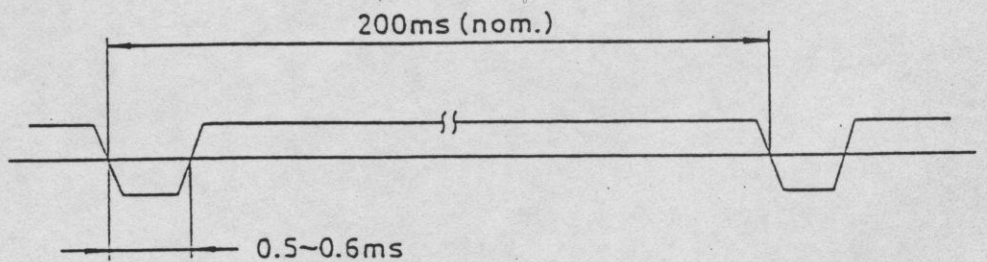

Fig. 1-24 : Index Pulse

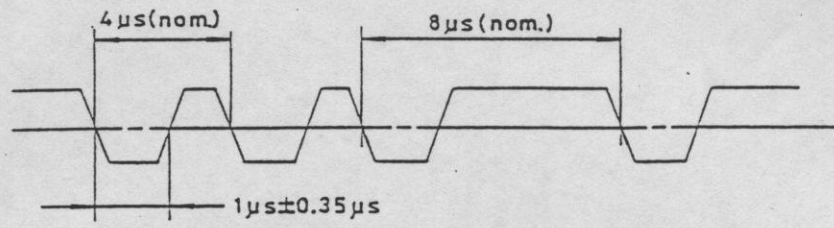

Fig. 1-25 : Read Data

(1) Seek Timing

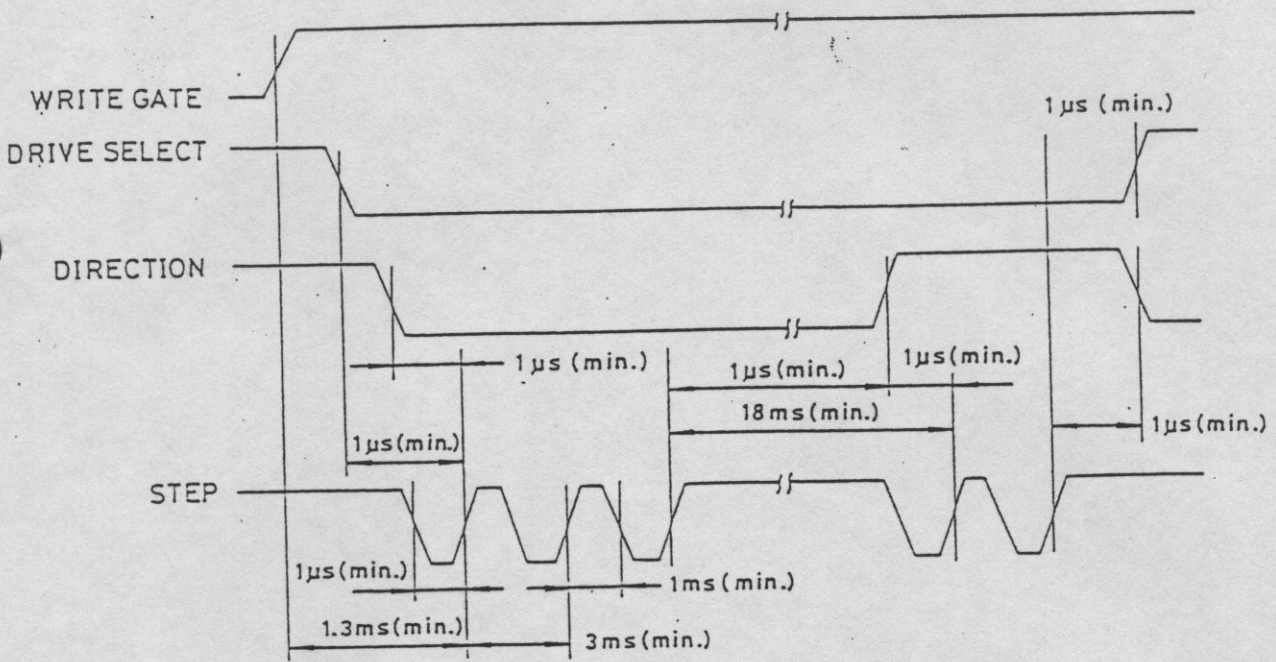

Fig. 1-26 : Step Timing

(2) Read Start Timing

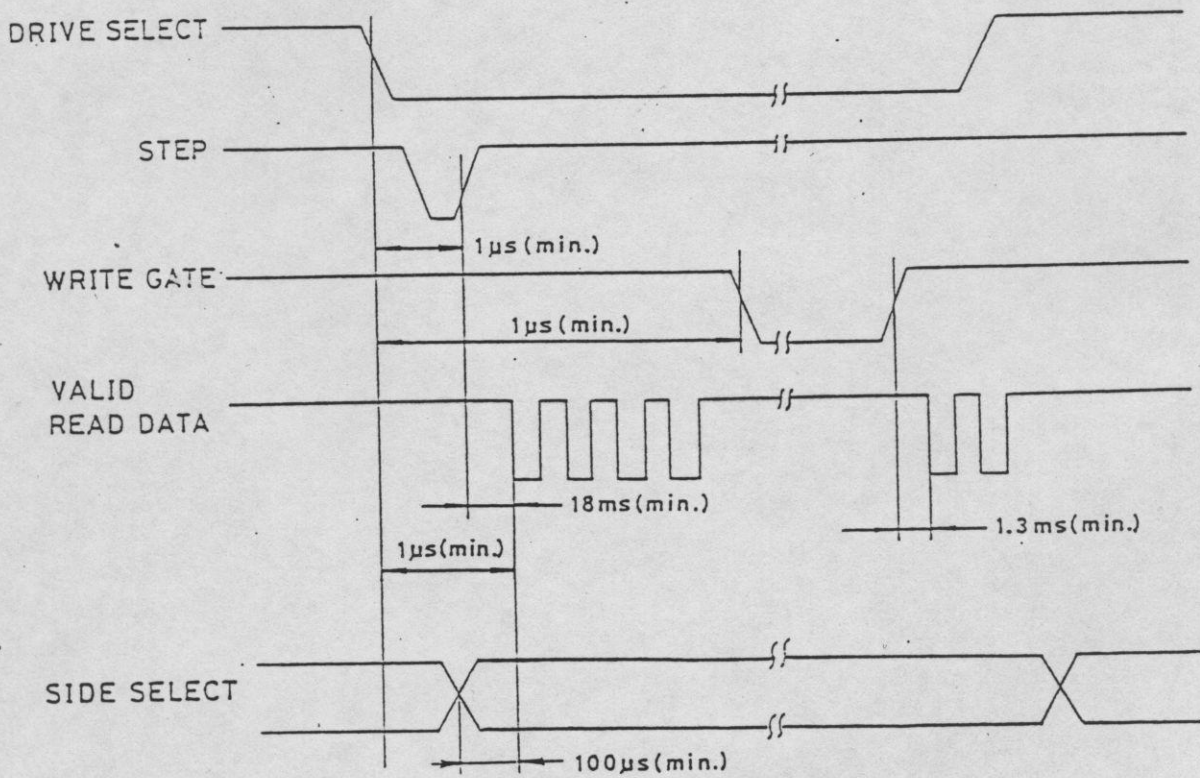

Fig. 1-27 : Read Start Timing

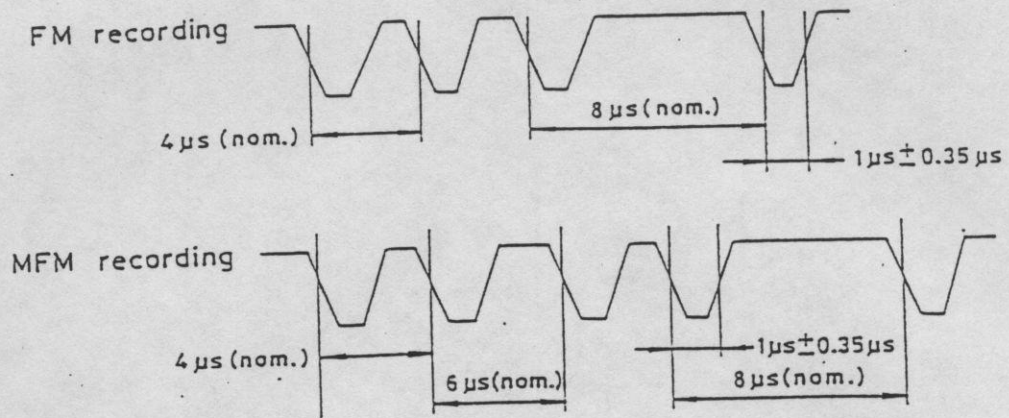

Fig. 1-28 : Read Data Timing

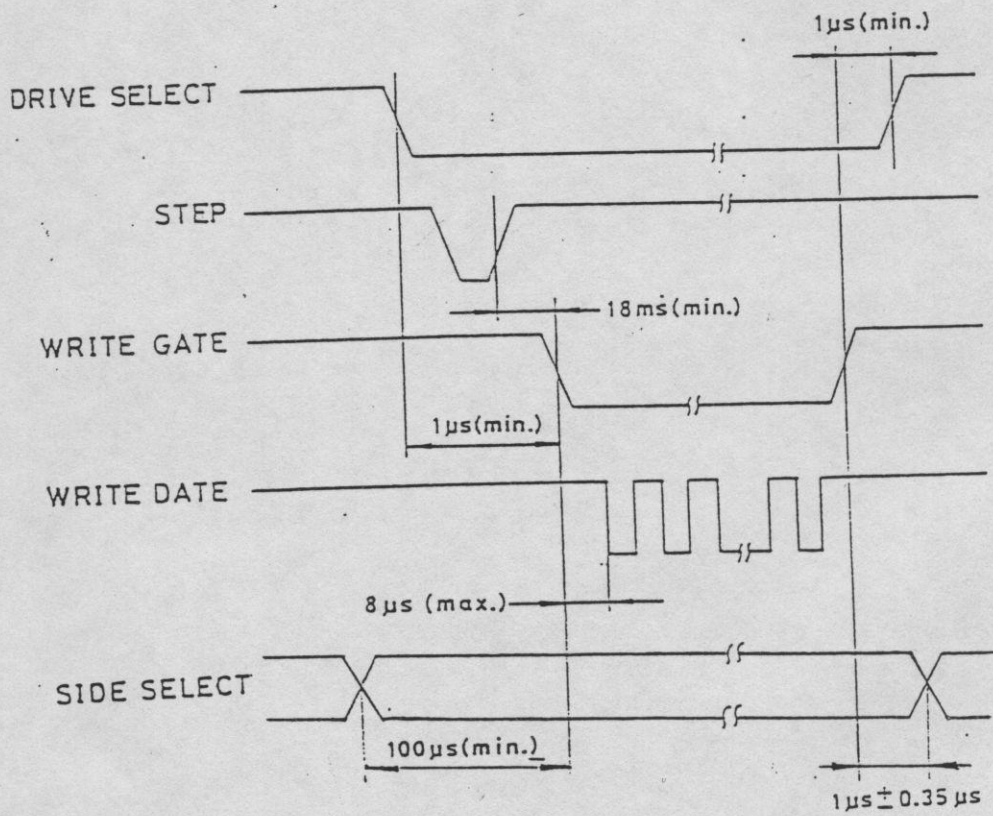

Fig. 1-29 : Write Start Timing

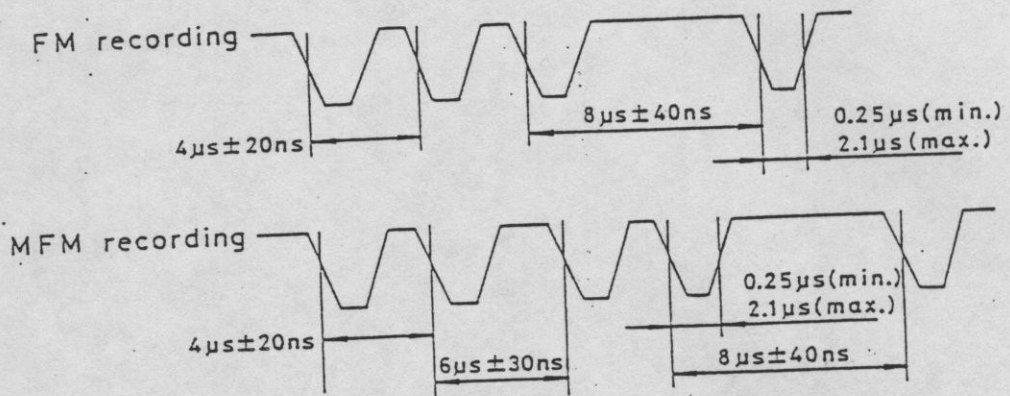

Fig. 1-30 : Write Data Timing

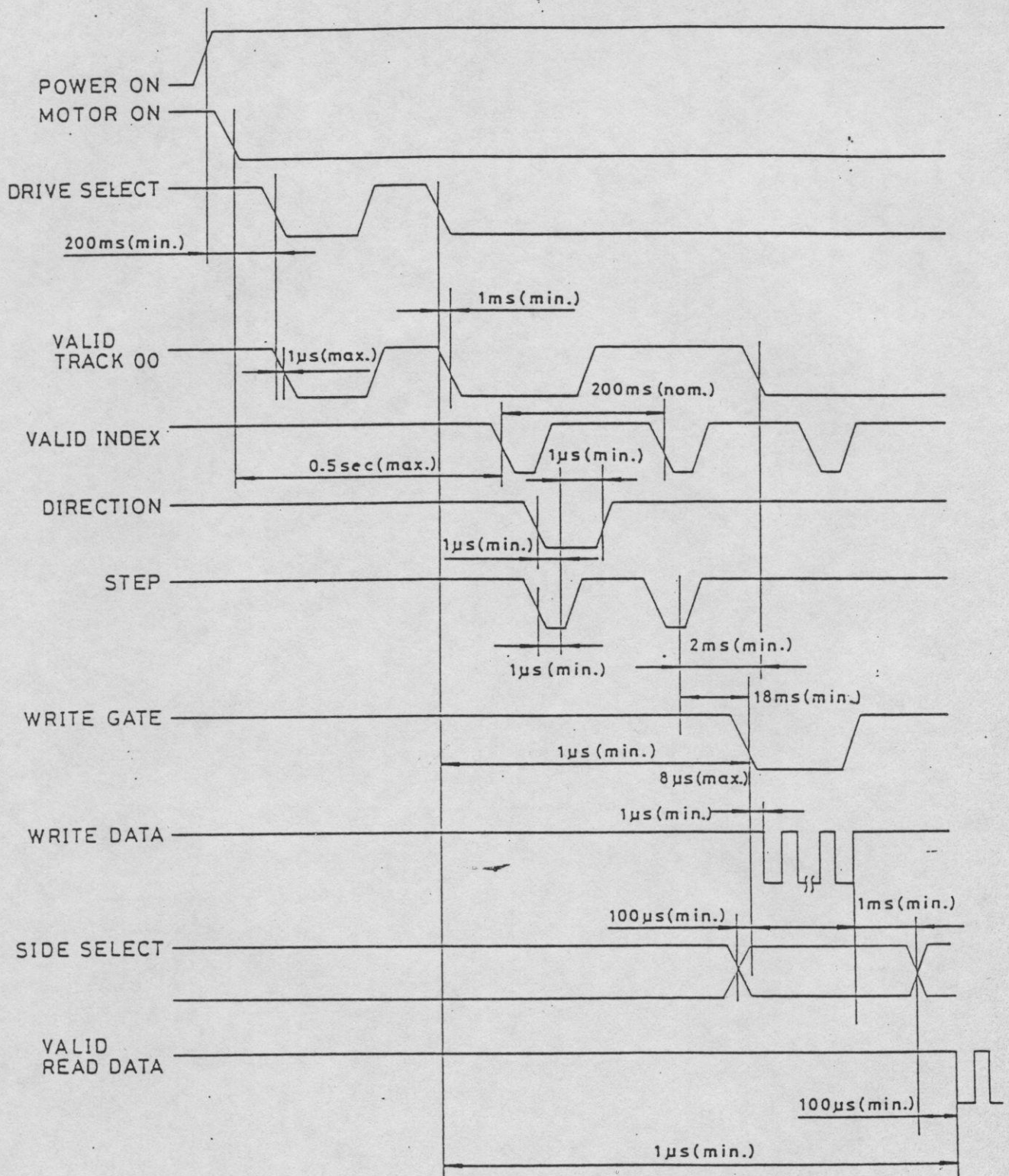

Fig. 1-31 : Control Data Timing

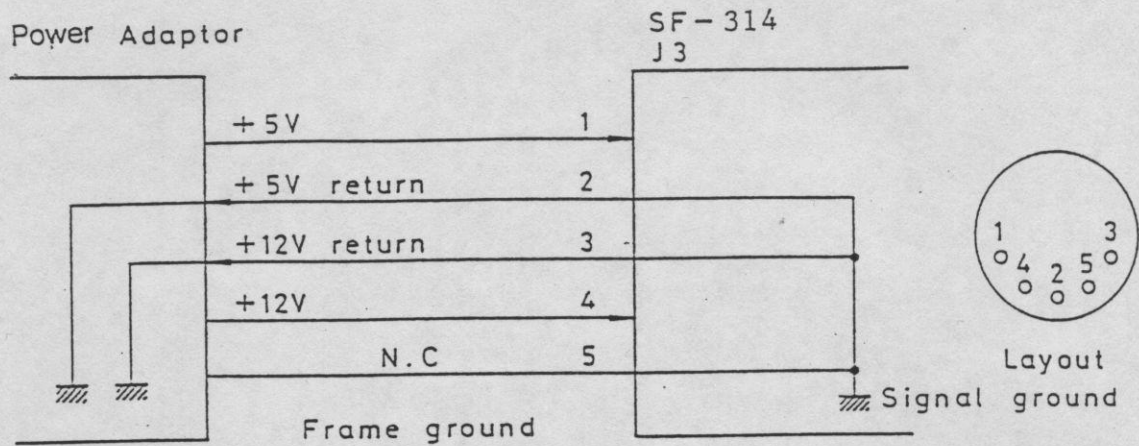

Fig. 1-32 : Power Supply

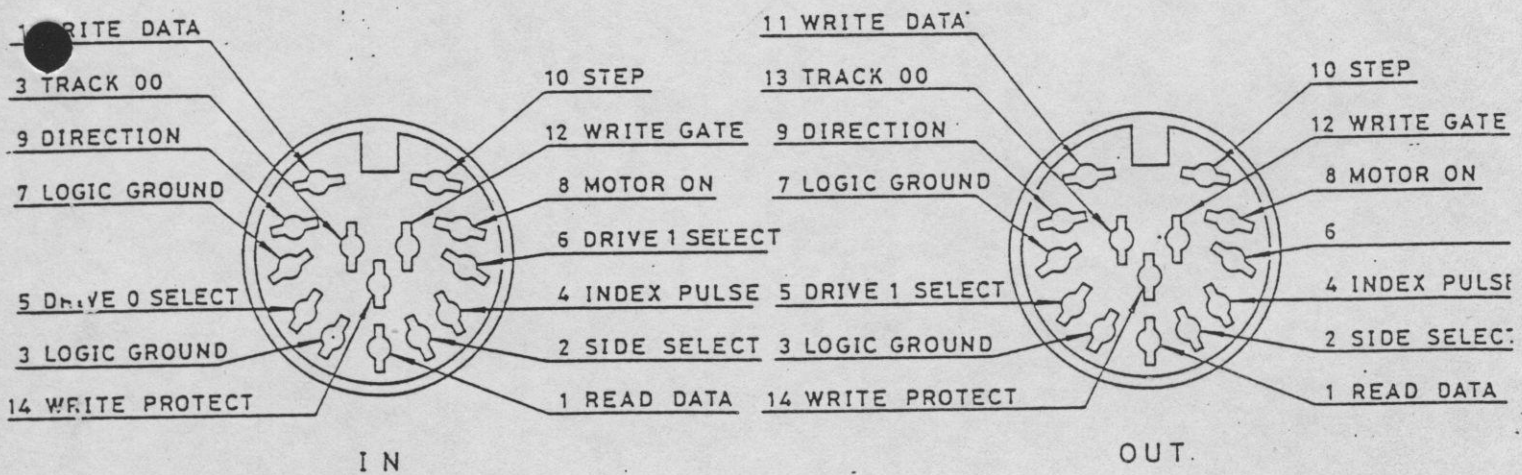

Fig. 1-33 : Signal Connector Layout

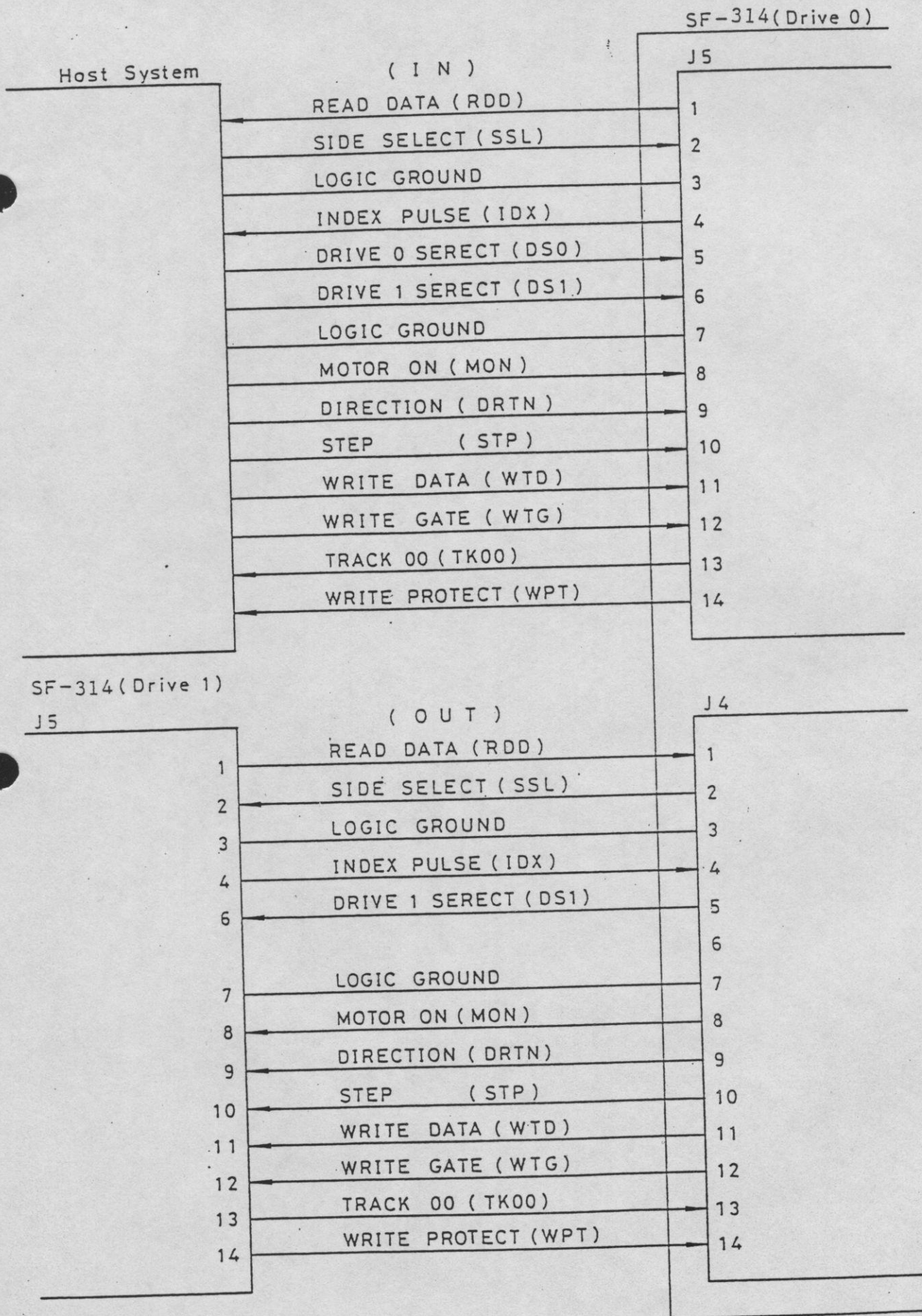
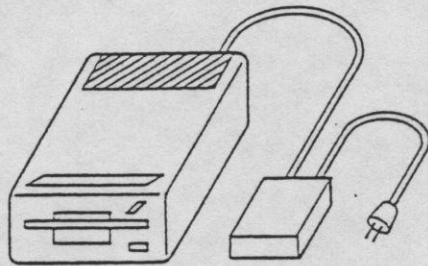

Fig. 1-34 : Signal Line



Horizontal Adaptor
Installation

(The PCB side must be up)

Fig. 1-35

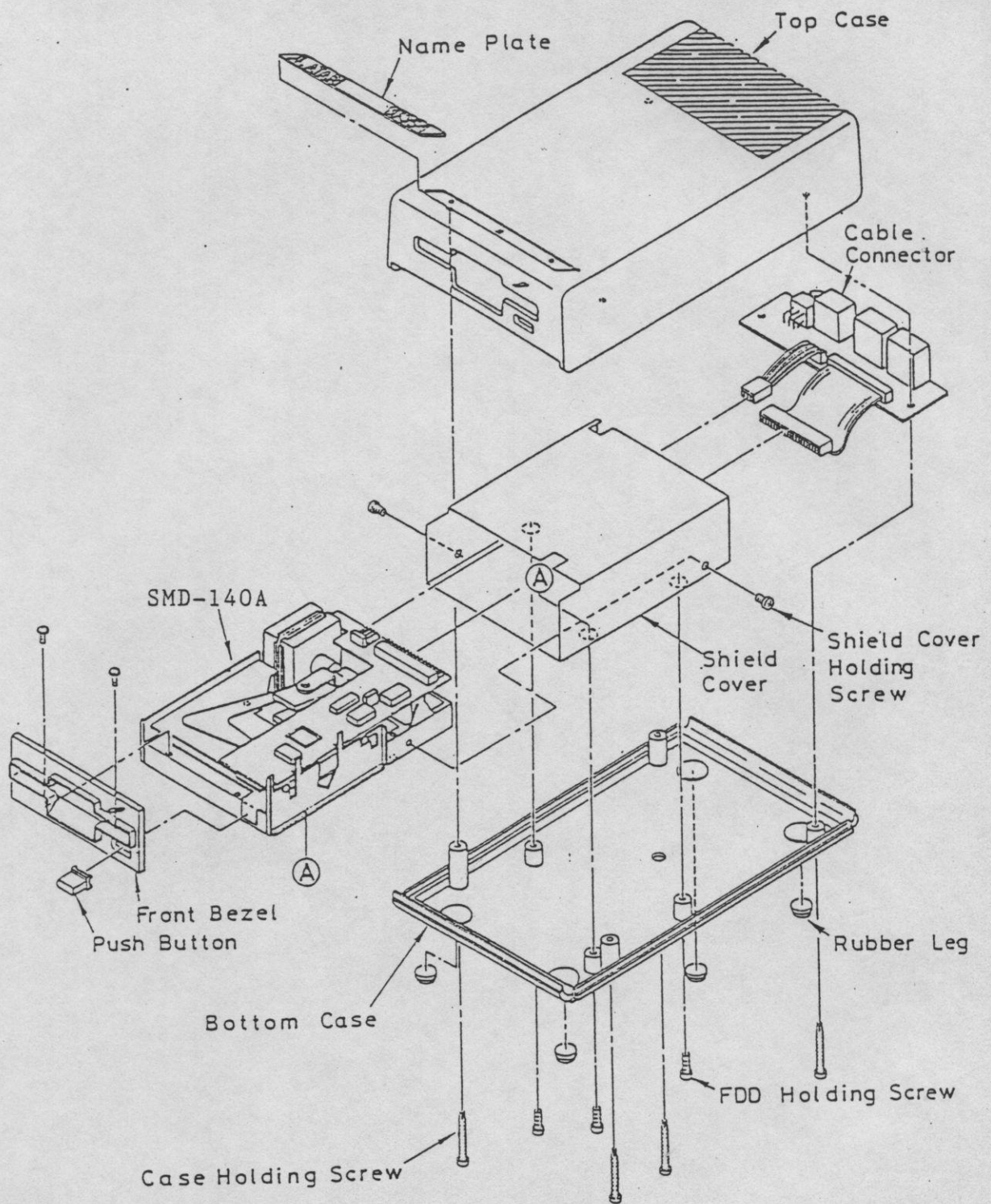
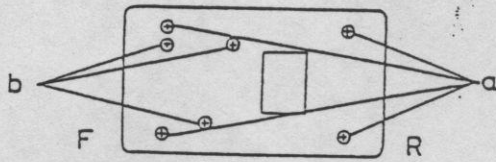

Fig. 3-1 : (SF314) Total Disassembly Drawing

Cross Bint Small
Screw
CBM3X16(3)



Cross Bint P
Tito Screw
CB3X30 S20(4)

Fig. 3-2

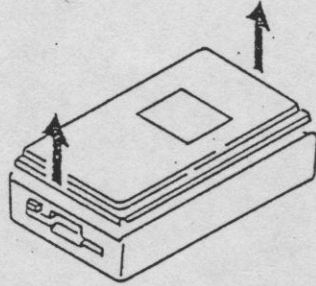

Fig. 3-3

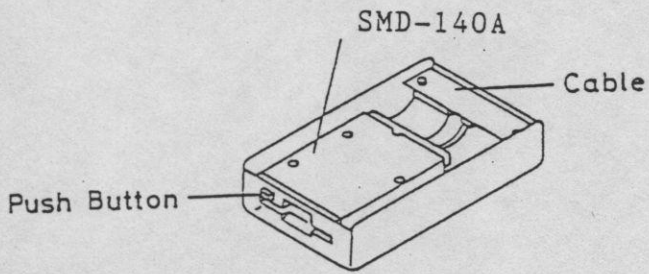

Fig. 3-4

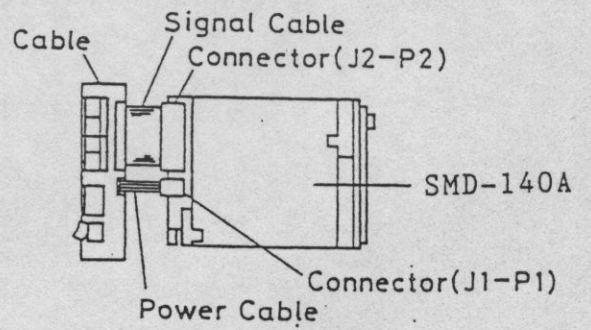

Fig. 3-5

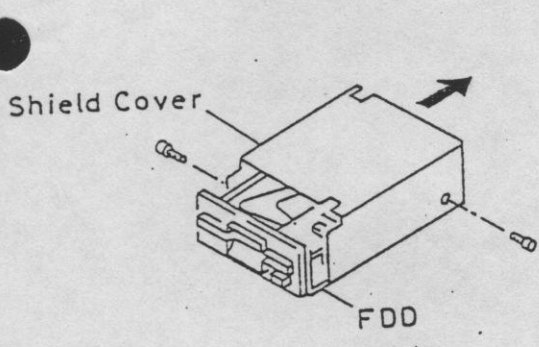

Fig. 3-6

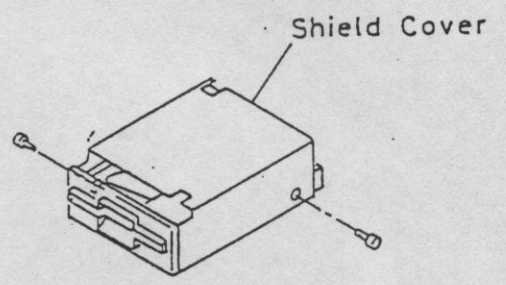

Fig. 3-7

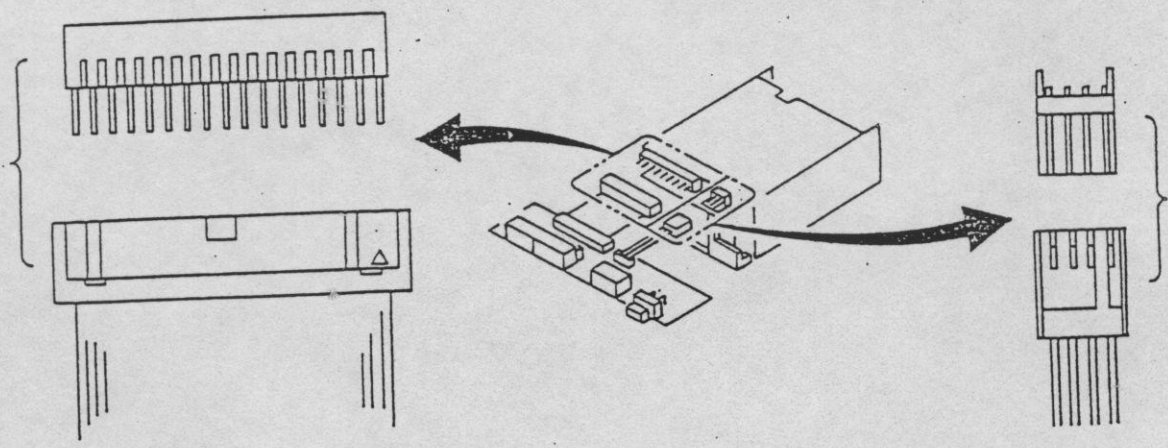

Fig. 3-8

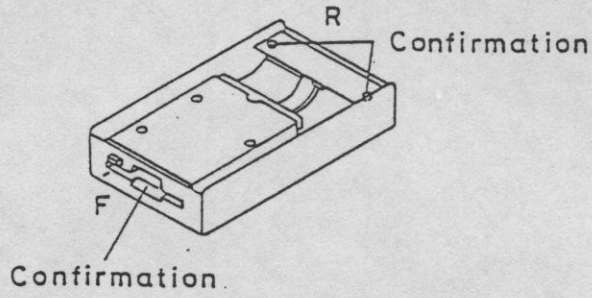
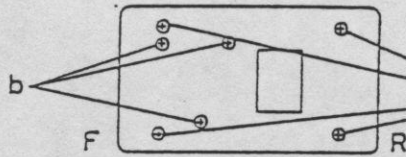

Fig. 3-9

Set Screw for FDD
 (Cross Bintl Small
 Screw
 CBM3X16(3))



Set Screw for
 Top Case
 (Cross Bintl P
 Tito Screw
 CB3X30 S20(4))

Fig. 3-10

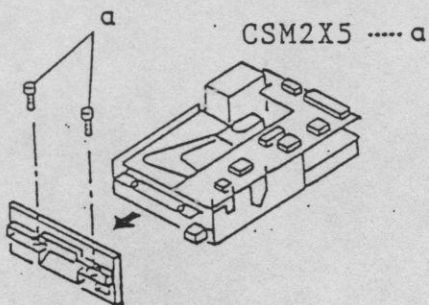

Fig. 3-11

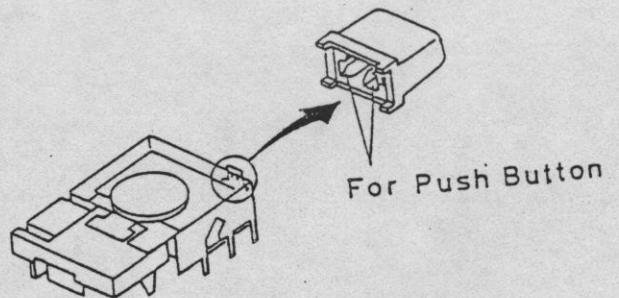

Fig. 3-12

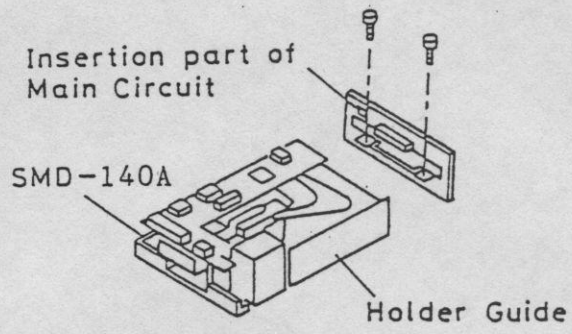

Fig. 3-13

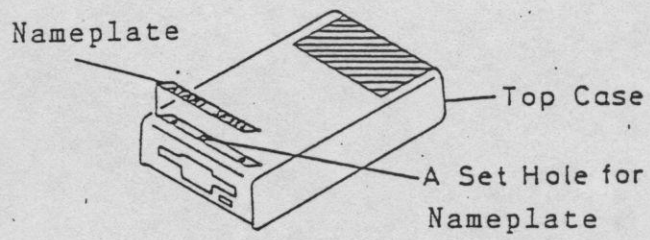
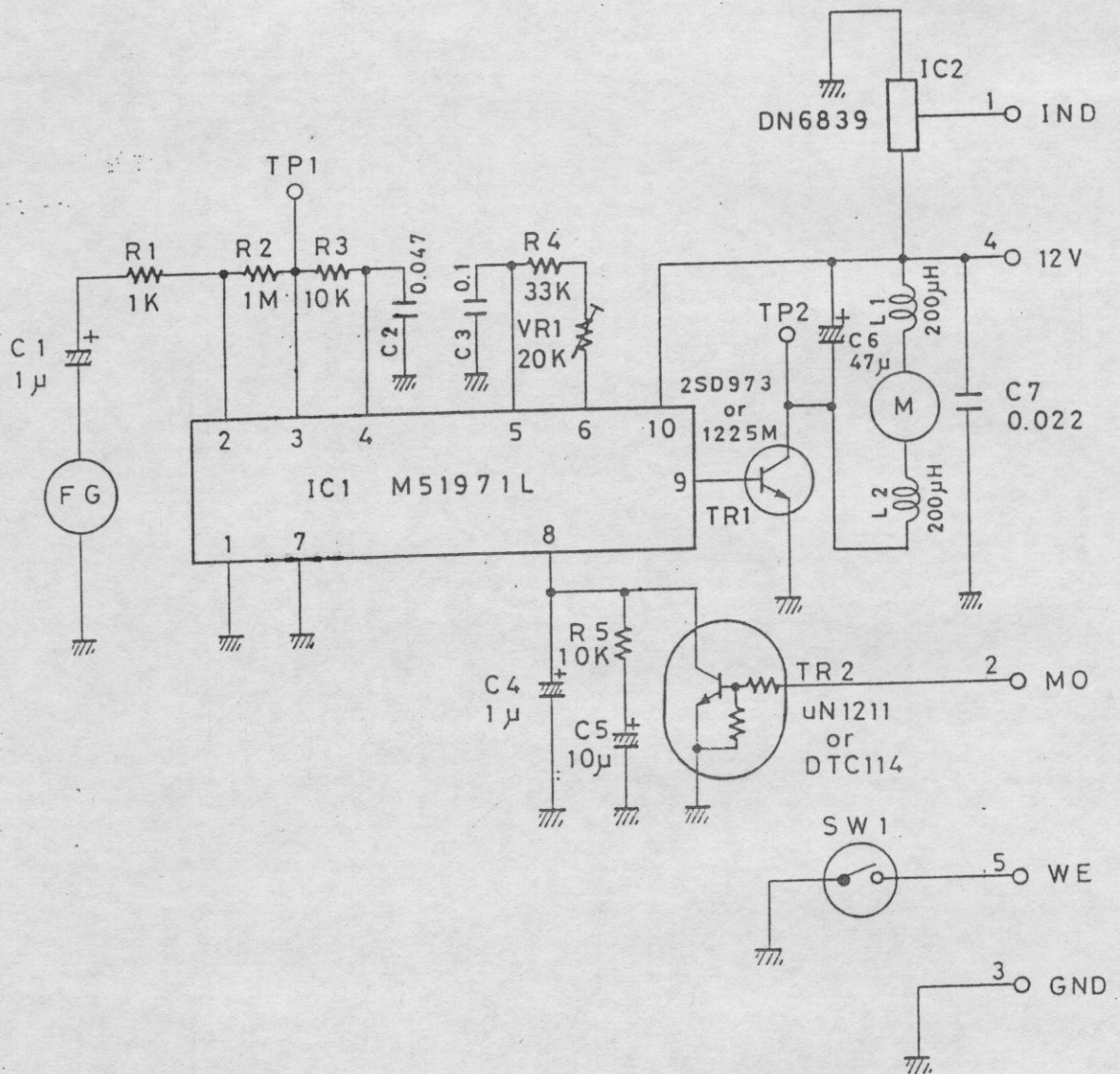
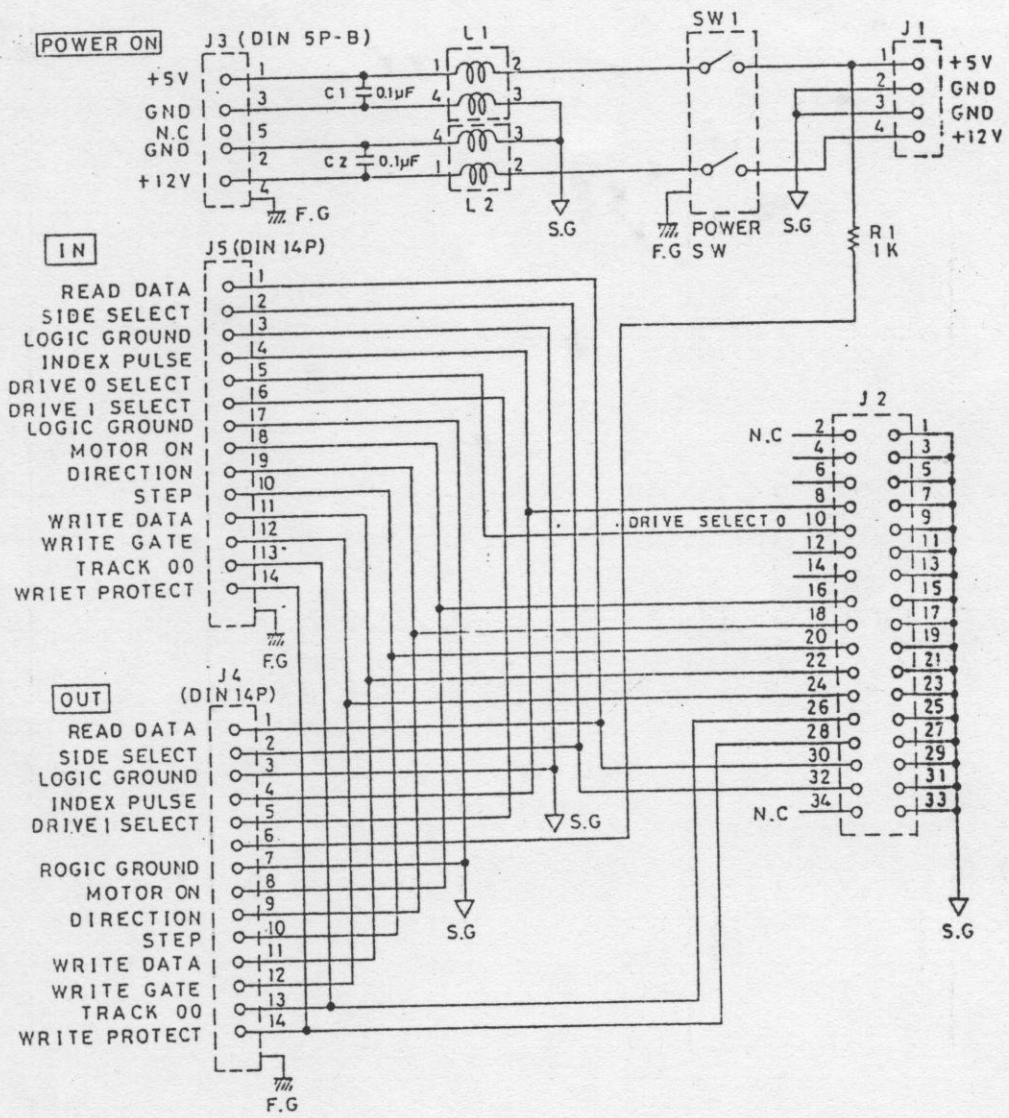

Fig. 3-14



MOTOR CIRCUIT BOARD



TF CONTROL BOARD

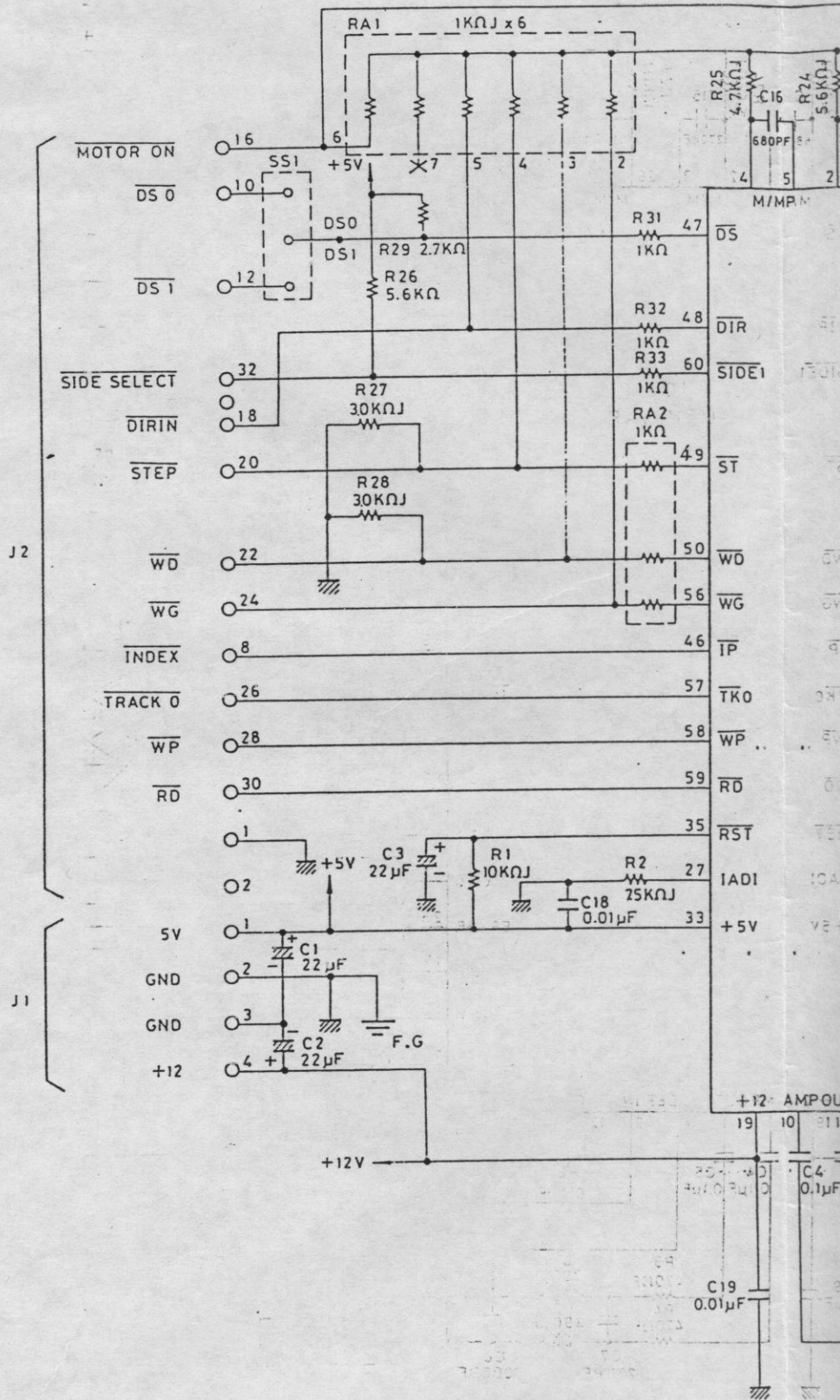

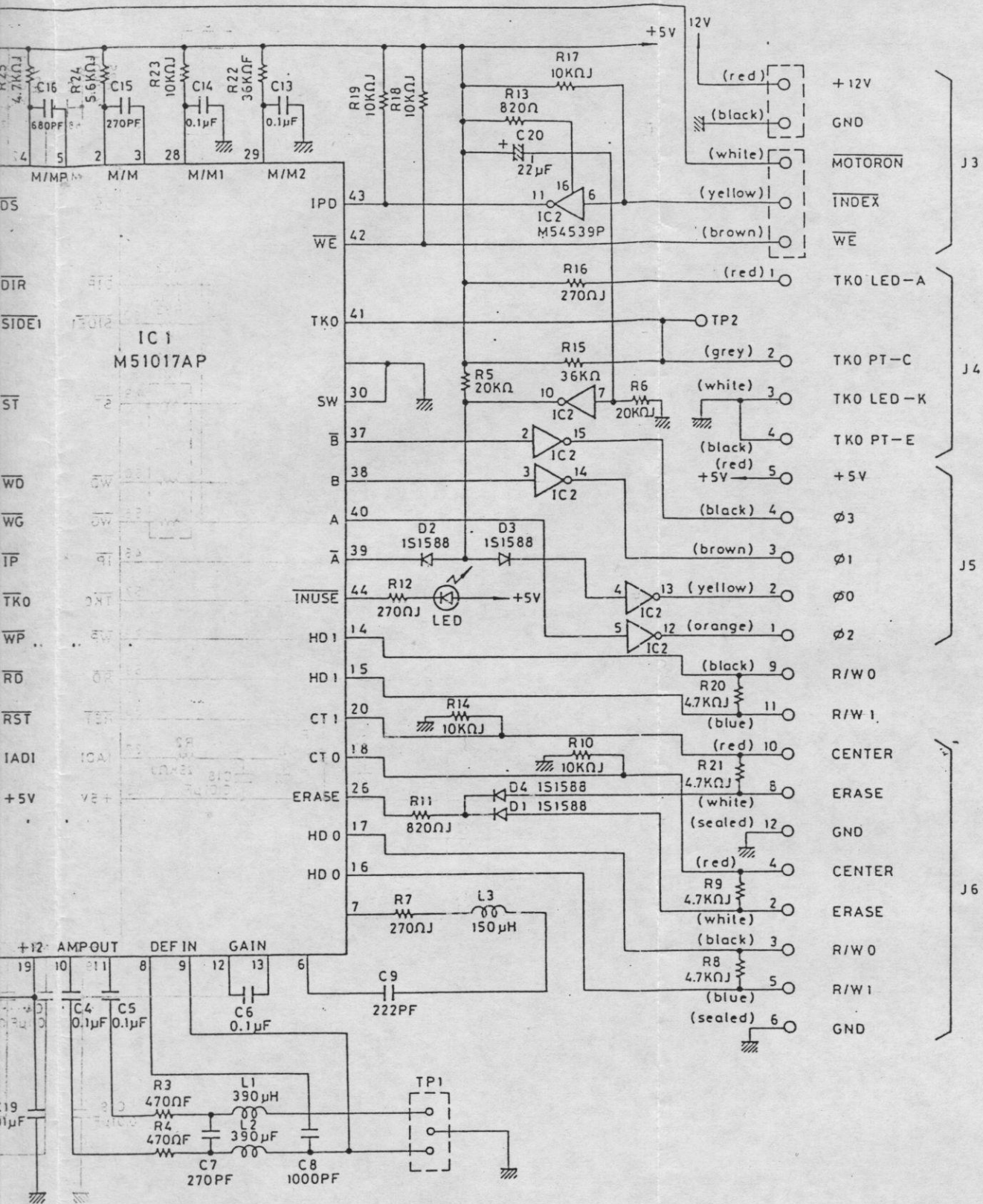

SMD-140A
MAIN BOARD

